

ECS 203 (ME2) - Part 2A

Dr.Prapun Sukksompong

CHAPTER 5

Operational Amplifiers

Operational amplifiers (or **Op Amp**) is an active circuit element that can perform mathematical operations between signals (e.g., amplify, sum, subtract, multiply, divide, integrate, differentiate).

- The ability of the op amp to perform these mathematical operations is the reason it is called an operational amplifier. It is also the reason for the widespread use of op amps in analog design.

Op amp is a building block of modern electronic instrumentation. Therefore, mastery of operational amplifier fundamentals is paramount to any practical application of electronic circuits. They are popular in practical circuit designs because they are versatile, inexpensive, easy to use, and fun to work with.

An op amp consisting of a complex arrangement of resistors, transistors, capacitors, and diodes. Here, we ignore the details.

The circuit symbol for the op amp is shown below.

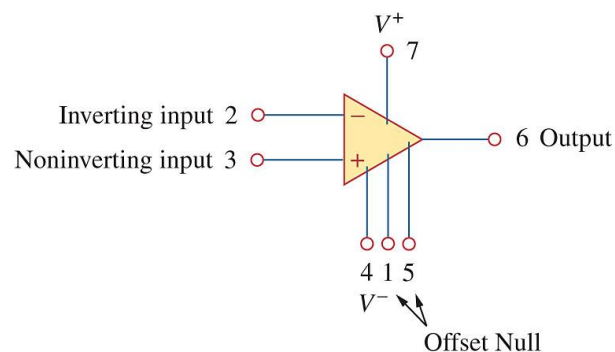

- It has two inputs and one output.
- The inputs are marked with minus (-) and plus (+) to specify inverting and noninverting inputs, respectively.

- An input applied to the noninverting terminal will appear with the same polarity at the output, while an input applied to the inverting terminal will appear inverted at the output.

As an active element, the op amp must be powered by a voltage supply:

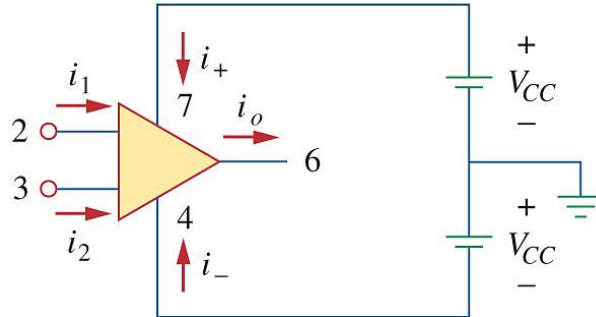

Although the power supplies are often ignored in op amp circuit diagrams for the sake of simplicity, the power supply currents must not be overlooked:

$$i_o = i_1 + i_2 + i_+ + i_-.$$

The equivalent circuit of non-ideal op amp is shown below. Note that the output section consists of a voltage-controlled source in series with the output resistance R_o .

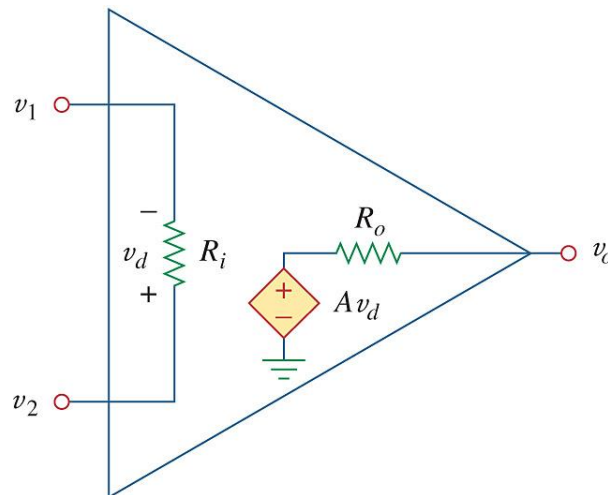

Input-output relations:

$$v_o = Av_d = A(v_2 - v_1)$$

where

v_0 = voltage between the output terminal and ground

v_1 = voltage between the inverting terminal and ground

v_2 = voltage between the noninverting terminal and ground

$v_d = v_2 - v_1$ = differential input voltage

A = open-loop voltage gain

- In words, the op amp senses the difference between the two inputs, multiplies it by the gain A , and causes the resulting voltage to appear at the output.

A is called the open-loop voltage gain because it is the gain of the op amp *without any external feedback* from output to input. Typical ranges for op amp parameters are shown in the following table Working

Parameter	Typical range	Ideal values
Open-loop gain, A	10^5 to 10^8	∞
Input resistance, R_i	10^5 to $10^{13} \Omega$	$\infty \Omega$
Output resistance, R_o	10 to 100 Ω	0 Ω
Supply voltage, V_{cc}	5 to 24 V	

with a nonideal op amp is tedious because it involves dealing with very large numbers.

5.1. Ideal Op-Amp

To facilitate understanding, we assume ideal op amps with the ideal values above.

DEFINITION 5.1.1. An *ideal op amp* is an amplifier with infinite open-loop gain, infinite input resistance, and zero output resistance.

Unless stated otherwise, we will assume from now on that every op amp is ideal.

Two important characteristics of the ideal op-amp:

- (a) The current into both input terminals are zero.

$$i_1 = 0, \quad i_2 = 0.$$

- (b) The voltage across the input terminals is negligibly small.

$$v_d = v_2 - v_1 \simeq 0$$

or

$$v_1 = v_2.$$

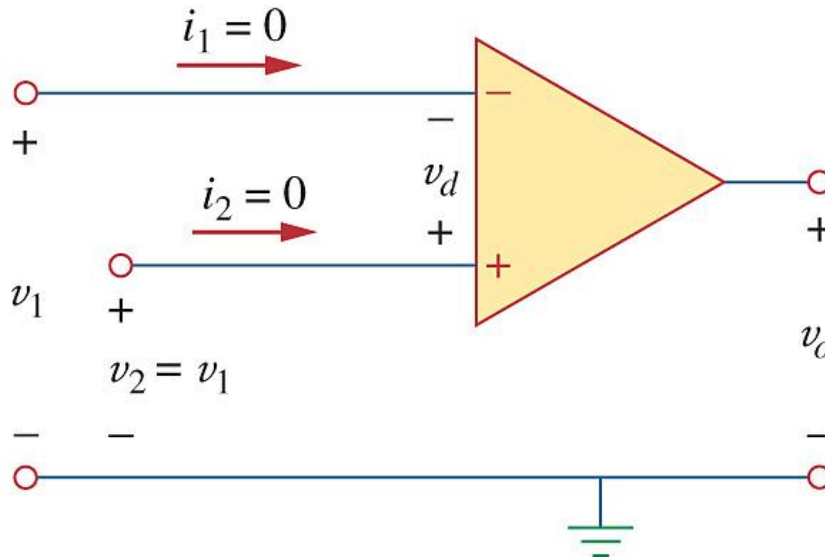

Ex.(ideal op amp with feedback) An ideal op amp is used in the circuit below. Find the closed-loop gain¹ v_o/v_s . Determine current i_o when $v_s = 1$ V.

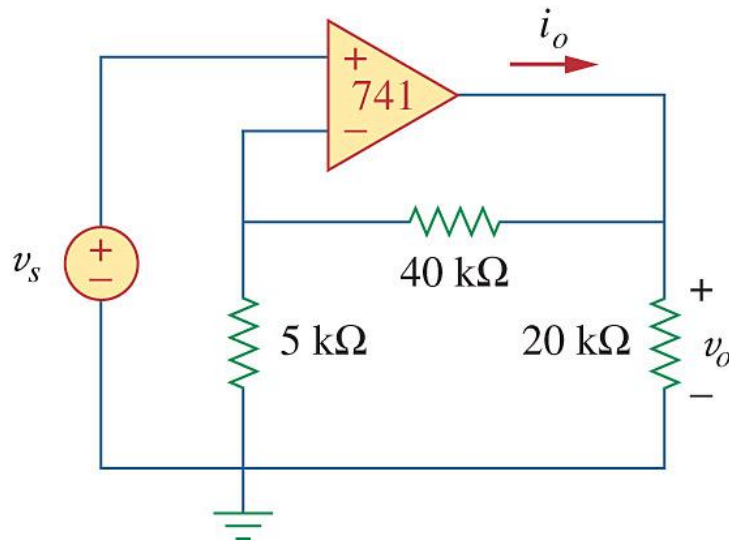

¹closed-loop gain = ratio of the output voltage to the input voltage.

5.2. Inverting Amplifier

Op amp can be used in circuits as modules for creating more complex circuits. The first of such op-amp circuits is the inverting amplifier which **reverses the polarity of the input signal while amplifying it.**

Let's say we want to amplify a small signal v_i by a factor of A_v and reverse its polarity as well, i.e., the output signal v_o is $v_o = -A_v v_i$. We can achieve this using an inverting amplifier. A key feature of the inverting amplifier is that both the input signal and the feedback are applied at the inverting terminal of the op amp.

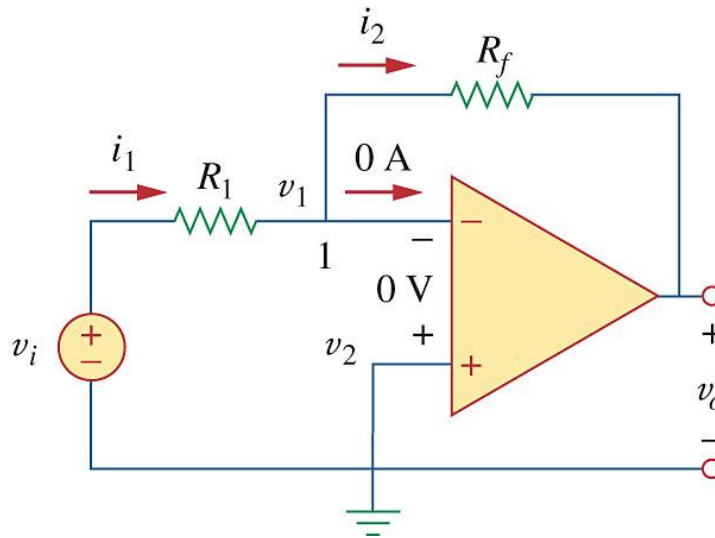

The equivalent circuit for the inverting amplifier is:

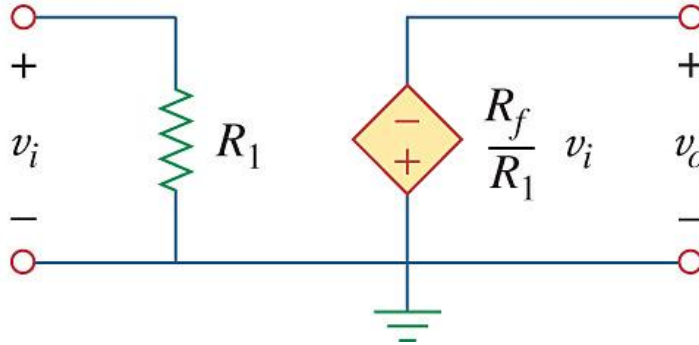

The voltage gain is $A_v = v_o/v_i = -R_f/R_1$.

5.3. Noninverting Amplifier

A noninverting amplifier amplifies a signal by a constant positive gain (no inversion of polarity). The circuit for a noninverting amplifier is

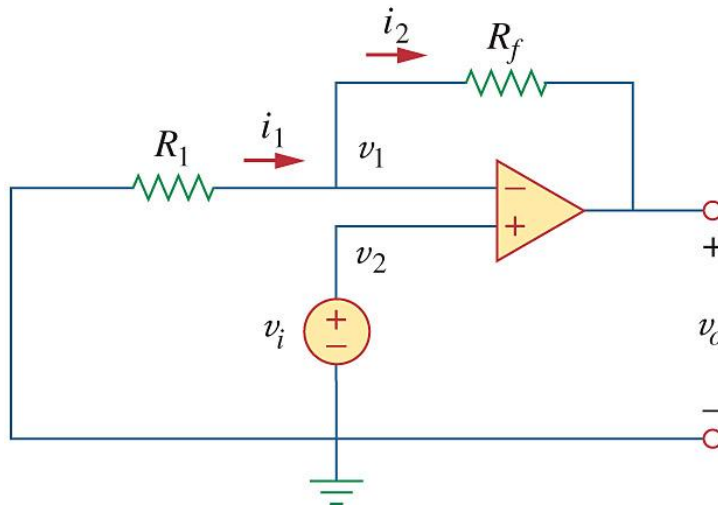

The voltage gain is $A_v = \frac{v_o}{v_i} = 1 + \frac{R_f}{R_1}$, which does not have a negative sign. Thus the output has the same polarity as the input.

Note: If $R_f = 0$ or $R_1 = \infty$, or both, the gain becomes 1. Under this conditions, the circuit becomes a *voltage follower* (The output follows the input).

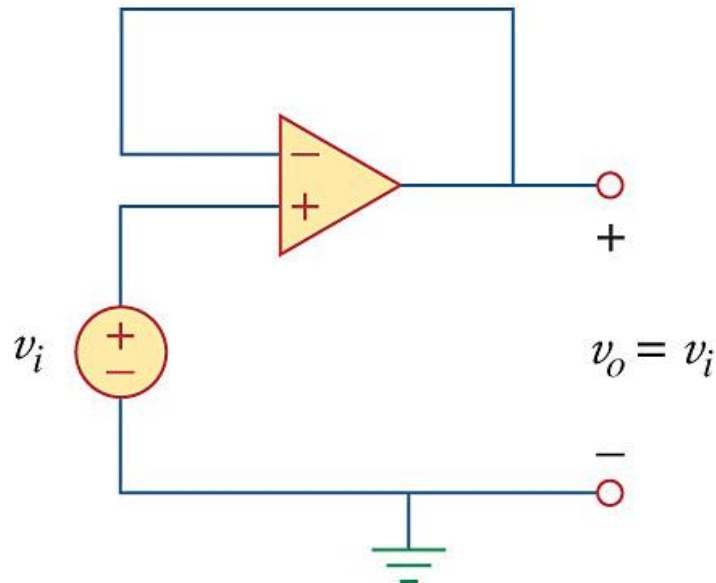

A voltage follower is used to isolate two cascaded stages of a circuit.

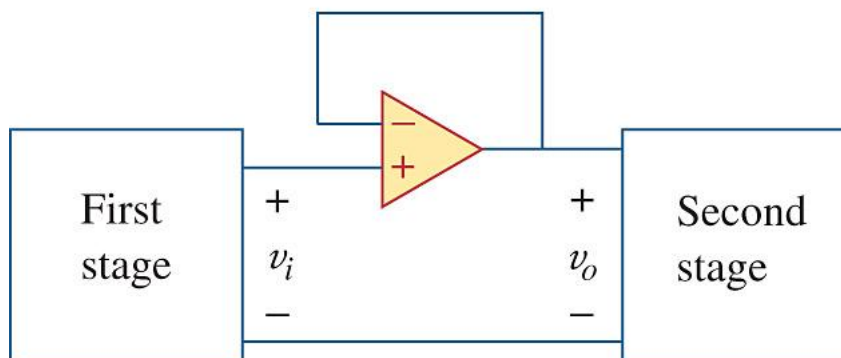

Ex. Calculate the output voltage v_o for the op amp circuit below.

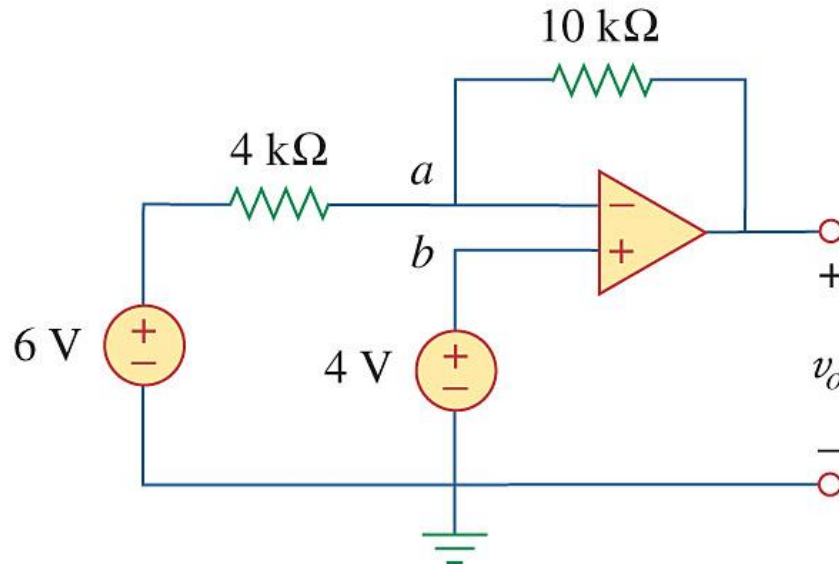

5.4. Summing Amplifier

A summing amplifier is an op-amp circuit that combines several inputs and produces an output that is the weighted sum of the inputs. For this reason, the circuit is called a *summer*.

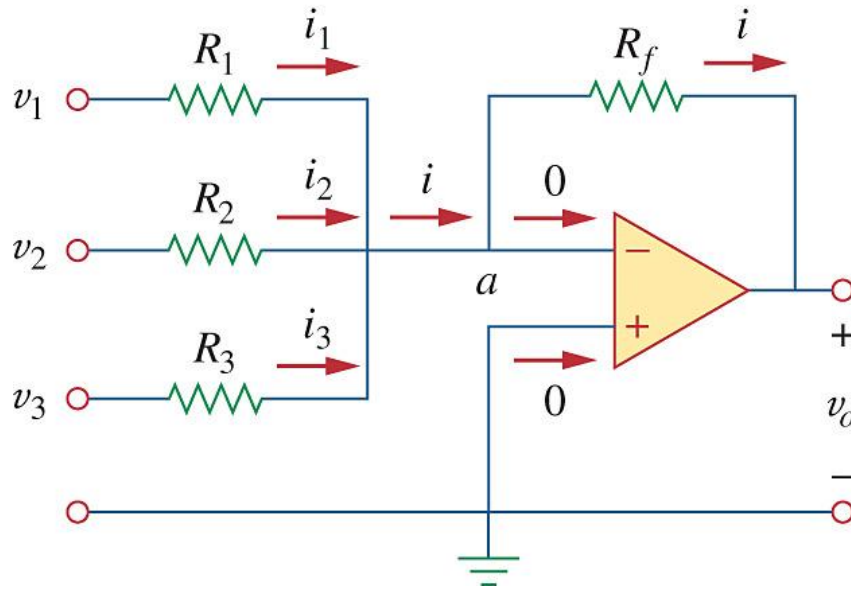

$$v_o = - \left(\frac{R_f}{R_1} v_1 + \frac{R_f}{R_2} v_2 + \frac{R_f}{R_3} v_3 \right).$$

Needless to say, the summer can have more than three inputs.

5.5. Difference Amplifier

A difference amplifier is a device that amplifies the difference between two inputs but rejects any signals common to the two inputs.

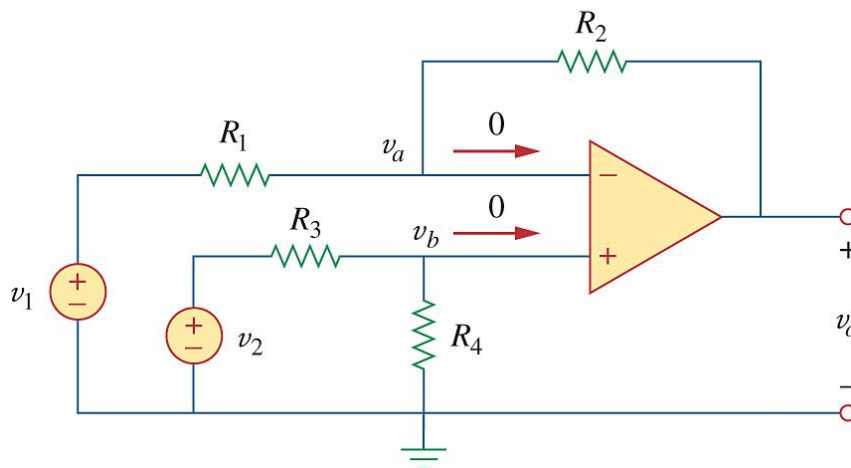

$$v_o = \frac{R_2(1 + R_1/R_2)}{R_1(1 + R_3/R_4)}v_2 - \frac{R_2}{R_1}v_1$$

Since a difference amplifier must reject a signal common to the two inputs, the amplifier must have the property that $v_o = 0$ when $v_1 = v_2$. This property exists when

$$\frac{R_1}{R_2} = \frac{R_3}{R_4}.$$

Thus,

$$v_o = \frac{R_2}{R_1} (v_2 - v_1).$$

If $R_2 = R_1$ and $R_3 = R_4$, the difference amplifier becomes a *subtractor*, with the output

$$v_o = v_2 - v_1.$$

Ex. Design an op amp circuit with inputs v_1 and v_2 such that

$$v_o = -5v_1 + 3v_2.$$

5.6. Cascaded of Op Amp Circuits

In practice, we can connect op amp circuits in cascade (i.e., head to tail) to achieve a large overall gain. Each circuit in the cascade is called **stage**. The output of one stage is the input to the next stage.

Op amp circuits have the advantage that they can be cascaded without changing their input-output relationships. This is due to the fact that each (ideal) op amp circuit has infinite input resistance and zero output resistance.

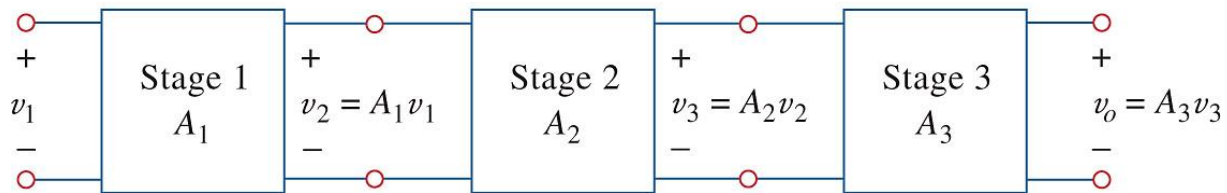

5.7. Application: Digital-to-Analog Converter (DAC)

The digital-to-analog converter (DAC) transforms digital signals into analog form. A typical example of a four-bit DAC is shown in (a) below.

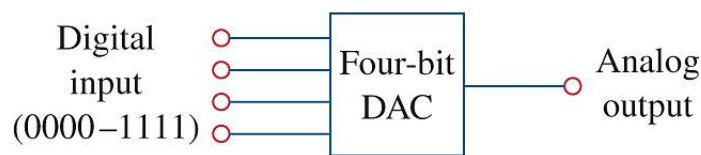

(a)

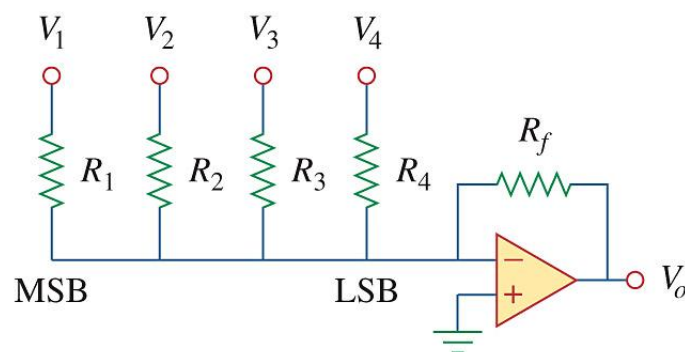

(b)

5.8. Application: Instrumentation(al) Amplifiers (IA)

One of the most useful and versatile op amp circuits for precision measurement and process control. IA amplifies the difference between the input signals.

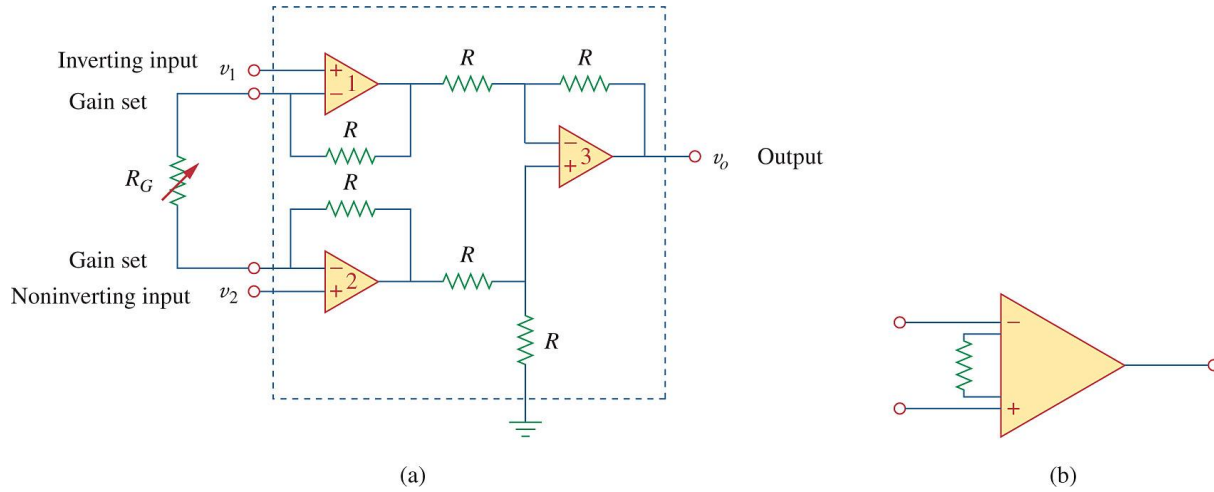

$$v_0 = \left(1 + \frac{2R}{R_G} \right) (v_2 - v_1).$$

The instrumentation amplifier amplifies small differential signal voltages superimposed on larger common-mode voltages. Since the common-mode voltages are equal, they cancel each other.

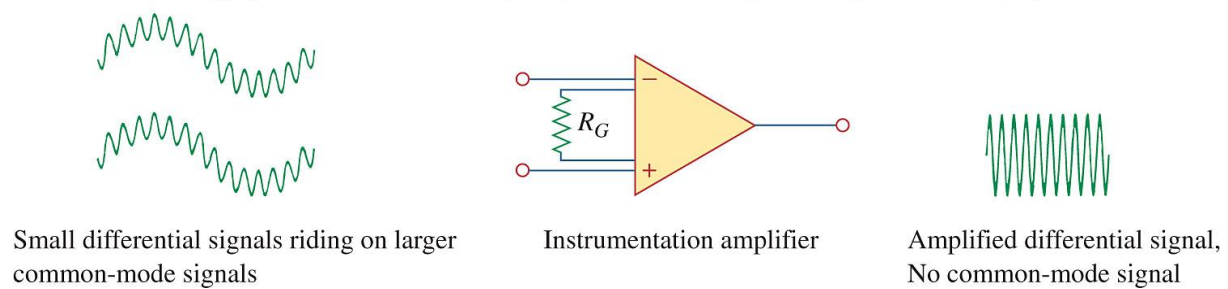

The IA has three major characteristics:

- The voltage gain is adjusted by one external resistor R_G .
- The input impedance of both inputs is very high and does not vary as the gain is adjusted.
- The output v_o depends on the difference between the inputs, not on the voltage common to them.

Typical example of IA has gain from 1 to 1000.