

Digital Circuits

ECS 371

Dr. Prapun Suksompong

prapun@siit.tu.ac.th

Lecture 1

Office Hours:

BKD 3601-7

Monday 1:30-3:30

Tuesday 10:30-11:30

Course Organization

- **Course Web Site:**

<http://www.siit.tu.ac.th/prapun/ecs371/>

- **Lectures:**

CS	IT
Room: BKD3216	Room: BKD3215
Time: 1. Mon 10:40-12:00 2. Thu 09:00-10:20	Time: 1. Tue 13:00-14:20 2. Thu 13:00-14:20

- **Textbook:**

- Thomas L. Floyd, [Digital Fundamentals](#), 10th Edition, Pearson Education International (2009).

- Companion Site:

http://wps.prenhall.com/chet_floyd_digitalfun_10/

- J. Wakerly, Digital Design: Principles & Practices, Prentice Hall, 3rd Edition (2001).



Course Web Site

- Please check the course Web site regularly.
- Announcement
- References
- Handouts/Slides
- Calendar
 - Exams
 - HW due dates

ECS371.PRAPUN.COM

ECS371: Digital Circuits

Announcements

- This site is still under construction. Please check back regularly. [Posted @ 10AM on June 3]

General Information

- **Instructor:** [Dr. Prapun Suksompong \(prapun@siit.tu.ac.th\)](mailto:prapun@siit.tu.ac.th)
- **Course Syllabus** (to be posted)
- **Class information**
- **Office Hours**
 - Monday : 1:30-3:30
 - Wednesday: 10:30-12:30
 - Room: BKD3601-7
 - **Please feel free to ask any question or express any concern after class.**
- **Required Textbook:** Thomas L. Floyd, *Digital Fundamentals*, 10th Edition, Pearson Education International (2009).
- **References**
 - Online Companion Site of the textbook: http://wps.prenhall.com/cher_floyd_digital_fun_10/
 - John Wakerly, *Digital Design Principles and Practices*, 4th Edition, Prentice-Hall (2005).

Handouts

- To be posted

Calendar

ECS371						
Today	June 2009	Week	Month	Agenda		
Sun	Mon	Tue	Wed	Thu	Fri	Sat
31	Jun 1	2	3	4	5	6
7	8	9	10	11	12	13
	Class: 10:30am C 10:40am E 1pm ECS:			9am ECS 1pm ECS:		
14	15	16	17	18	19	20
	10:40am E 10:30am C 1:30pm Of 1pm ECS:			9am ECS 1pm ECS:		
21	22	23	24	25	26	27
	Last day +2 more	First Day +2 more		9am ECS 1pm ECS:		
28	29	30	Jul 1	2	3	4
	10:40am E 10:30am C 1:30pm Of 1pm ECS:			9am ECS 1pm ECS:		

Grading System

- Coursework will be weighted as follows:

Homework	10%
Class Participation and Quizzes	20%
Midterm Examination •13:30 - 16:30 on Jul 30, 2009	30%
Final Examination (comprehensive) •13:30 - 16:30 on Oct 1, 2009	40%

- Mark your calendars now!
- Late HW submission will be rejected.
- All quizzes and exams will be closed book. Calculators are **not** allowed.

Policy

This does not mean that I will leave the lecture room immediately after class. I will stay and answer questions.



- We will start the class **on time** and will finish **on time**.
 - 10 min late = absence.
 - Raise your hand and tell me immediately if I go over the time limit.
- Mobile phones *must* be set to the silent mode.
- We will have some pop quizzes (without prior warning or announcement).
- Cheating will not be tolerated.
- **New policy**: Copying homework/quiz = cheating
 - First time cheater receives zero on that assignment.
 - Second time cheater receives zero on all quizzes and/or HWs.

Policy (con't)

- Attendance and pop quizzes will be taken/ given irregularly and randomly.
- Class participation is highly encouraged.
 - It does not mean simply sitting quietly in the class.
 - Feel free to stop me when I talk too fast or too slow.
 - Ask question! Don't be shy!
 - If you don't understand something, there is a good chance that your friends do not understand as well.
- You may be called upon to complete exercises in front of the class at any time.
 - Emphasis on EFFORT and METHODOLOGY, not right or wrong answers.
- I will surely make some mistakes in lectures / HWs / exams
 - Some amount of class participation scores will be reserved to reward the first student who inform me about each of these mistakes.

More Policy

- Get some help!
 - Do not wait until the final exam time or after the grade is out
- Office Hours (BKD-3601)
 - **Monday 1:30-3:30**
 - **Tuesday 10:30-11:30**
 - Appointment can be made if needed.
 - Feel free to come to my office and chat!
- You may also ask question after class.
- Points on quizzes/exams are generally based on your entire solution, not your final answer.
 - You can get full credit even when you have the wrong final answer.
 - You may get zero even when you write down a right answer if you do not justify your answer.

Warning

- This class can be difficult if you don't keep up with the lectures
- I will **evaluate** your understanding of the course **regularly** through
 - In class problems where you are asked to answer short questions in front of the class
 - Quizzes
 - Exams



Course Outline

1. Introduction to digital circuits, number systems, signed numbers, arithmetic operations
2. Logic gates and Boolean algebra (DeMorgan's theorem, truth tables)
3. Combinational logic circuits (SOP and POS forms)
4. Combinational logic circuits (Karnaugh maps)
5. Arithmetic circuits (adders, subtractors, multipliers)
6. MSI logic circuits (encoders, decoders, 7-segment LED, multiplexers, comparators)
7. MIDTERM: 13:30 - 16:30 on Jul 30, 2009
8. Sequential logic circuits (latches, flip-flop)
9. Sequential logic circuits (analysis and design)
10. Sequential logic circuits (counters, shift registers, digital filters)
11. Memory and storage
12. Programmable logic devices (PLD, FPGA)
13. Hardware description language (HDL)
14. Integrated Circuit Technologies
15. FINAL: 13:30 - 16:30 on Oct 1, 2009

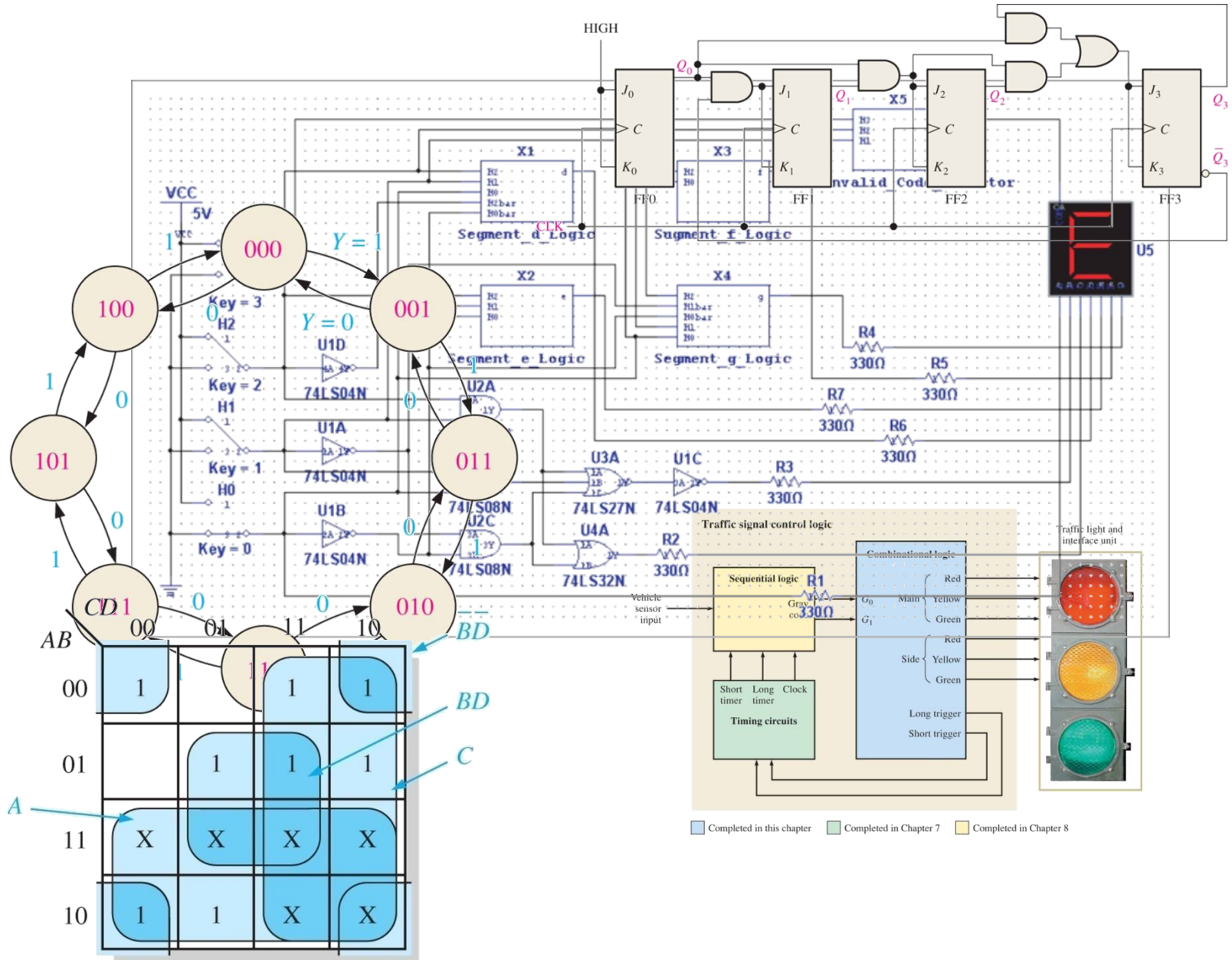

 Completed in this chapter
 Completed in Chapter 7
 Completed in Chapter 8

Tips

- This course may seem to be simple at the beginning.
 - We need to review some basic concepts.
 - Use this stage to learn new terminology and my teaching style
- It will get harder.
 - The materials build up.
- Make sure that, before you come to the new lecture, you understand the material presented during the earlier lectures.

Life after ECS 371

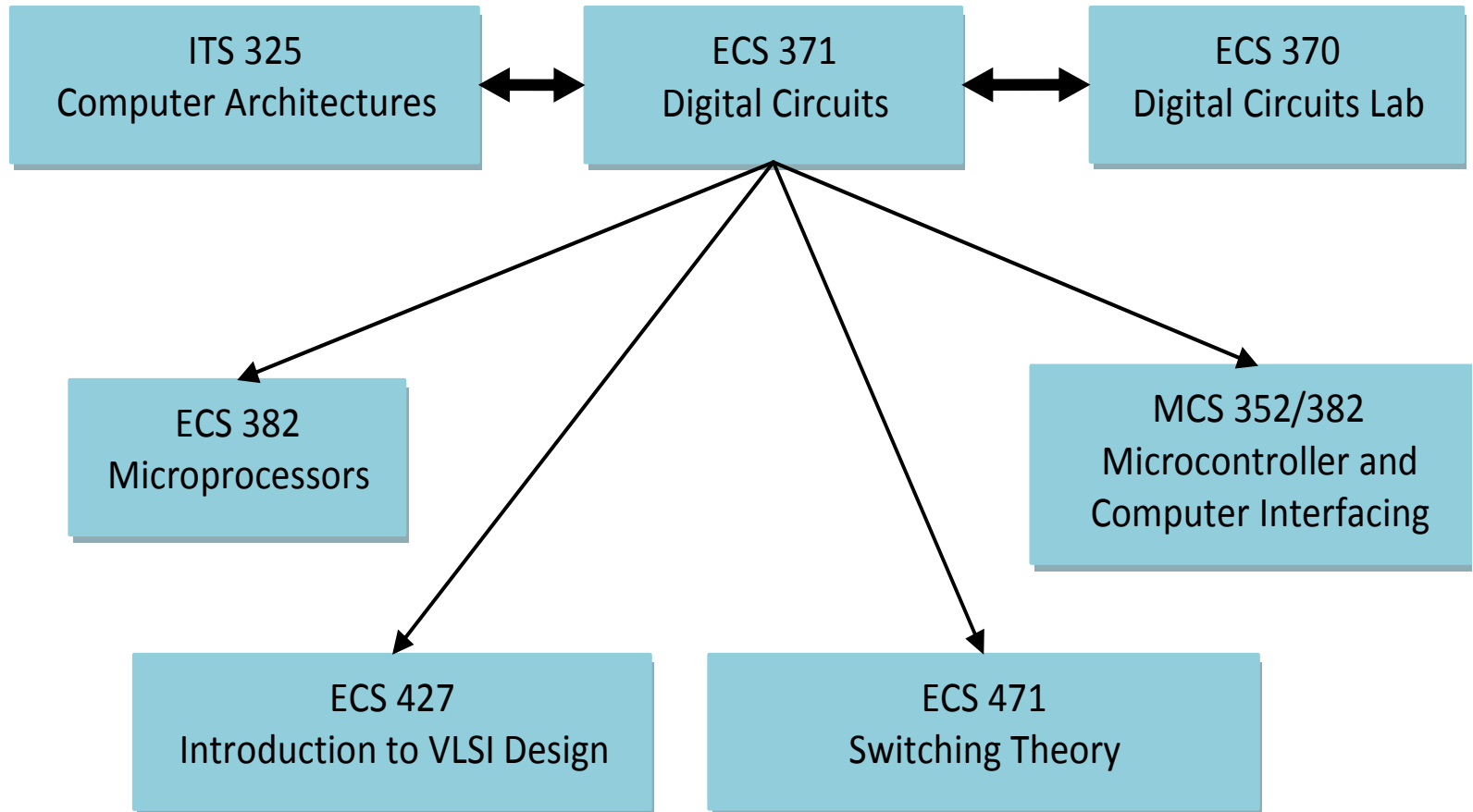

Credits

- Prof. Thomas L. Floyd (Book author)
- Prof. Adam W. Bojanczyk (Cornell)
- Dr. Wesley E. Swartz (Cornell)
- Dr. Douglas Long (Cornell)
- Dr. Itthisek Nilkhamhang (SIIT)

Reading Assignment

Chapter 1 and Chapter 2 (from Floyd)

- 1 Introductory Concept
 - 1-1 Digital and Analog Quantities
 - 1-2 Binary Digits, Logic Levels, and Digital Waveforms
- 2 Number Systems, Operations, and Codes
 - 2-1 Decimal Numbers
 - 2-2 Binary Numbers
 - 2-3 Decimal-to-Binary Conversion
 - 2-4 Binary Arithmetic
 - 2-5 1's and 2's Complements of Binary Numbers

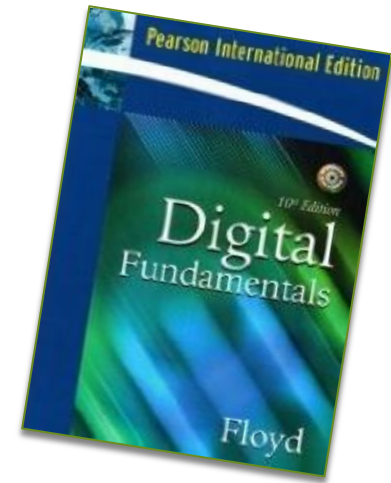

Digital and Analog Quantities

- An **analog** quantity is one having **continuous** values.
- A **digital** quantity is one having a **discrete** set of values
- The **real world is analog!**
 - Most things that can be measured quantitatively occur in nature in analog form.
 - Examples: air temperature, pressure, distance, sound.
- Interfacing between analog and digital is important.
- Digitization
 1. **Sampling:** Discretize the time
 - Get sampled values of the analog signal.
 2. **Quantization:** Discretize quantity values
 - Convert each sampled value to a binary code.

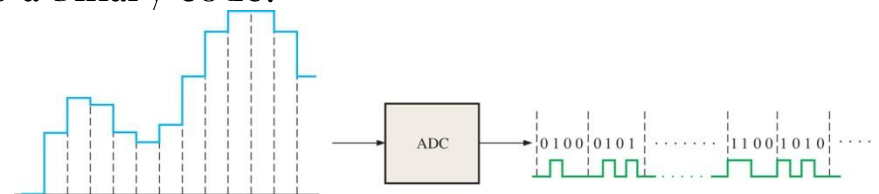
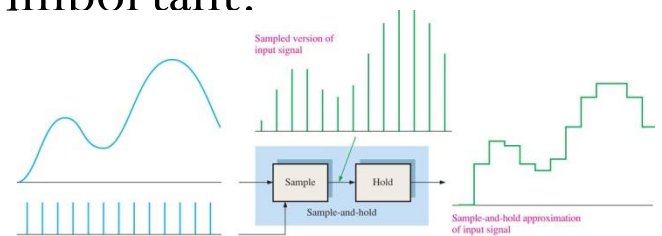

Digitization

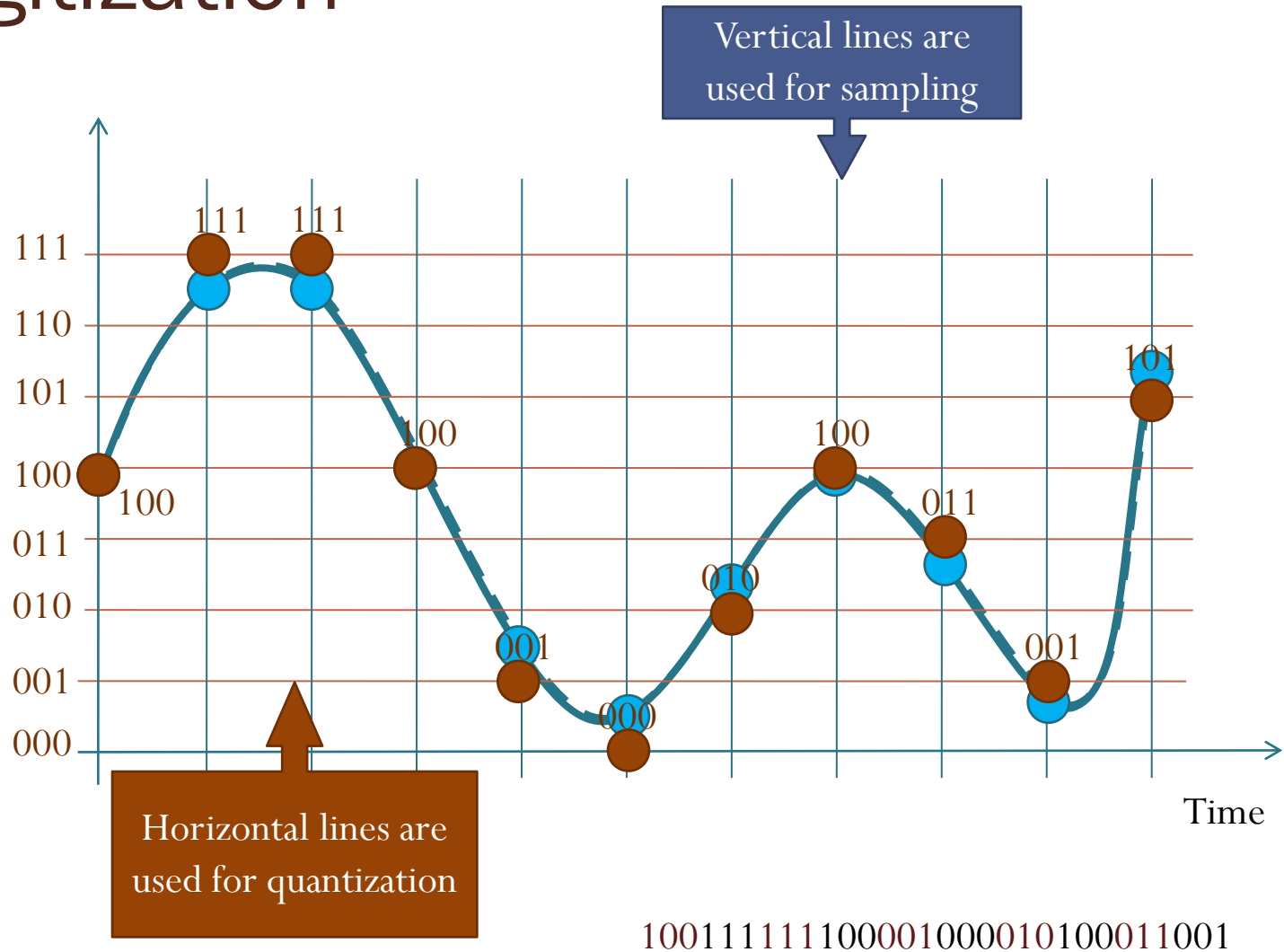

Analog and Digital Systems

- Many systems use a mix of analog and digital electronics to take advantage of each technology.
- A typical CD player accepts digital data from the CD drive and converts it to an analog signal for amplification.

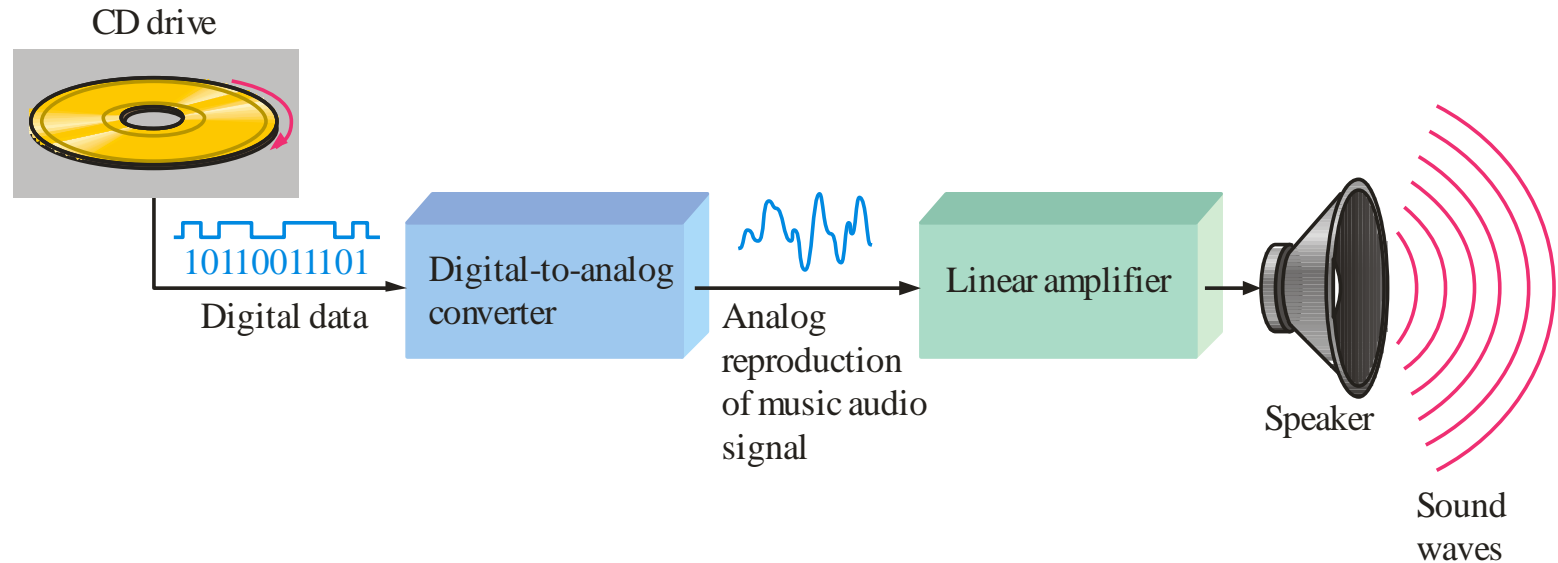

Digital vs. Analog Data Representation

- Problems with analog?
 - Hard to measure an exact value.
 - Noise (or interference) may disrupt signal.
 - Signal is hard to maintain across large distances.
- Digital systems can process, store, and transmit data more efficiently but can only assign discrete values to each point.
 - Noise (unwanted voltage fluctuations) does not affect digital data nearly as much as it does analog signals.
 - Can use error-correcting codes.
 - Can use compression.
- Analog systems can generally handle higher power than digital systems.
- The **real world is analog!**
 - Even digital systems are really analog deep down.

What is ECS 371?

- We study digital logic circuits.
- In particular, this course introduces procedures for the **analysis** and **design** of digital logic circuits.
- Two important ideas that you should keep in mind:
 - Abstraction
 - Hierarchy

Applications of Logic Design

- Conventional computer design
 - CPUs, busses, peripherals
- The digital world is much bigger than just PCs!
- Networking and communications
 - Phones, modems, routers
- Embedded products
 - Cars (ABS, carburetion, light controls)
 - Toys (motion and talking)
 - Appliances (timing and sensing)
 - Entertainment devices (games)
- Scientific equipment
 - Testing, sensing, reporting

Binary System

- **Digit**: A symbol used to express a quantity.
- **Digital**: Related to digits or discrete quantities; having a set of discrete values as opposed to continuous value.
- **Digital electronics** involves circuits and systems in which there are only *two* possible states represented by *two* digits.
- The two-state number system is called **binary system**
 - Its two digits are 0 and 1. Each of the two digits is called a **bit**, which is a contraction of the words **binary digit**.
- Information in circuits are represented by voltage values.
- **Positive Logic System**: 0 and 1 are represented by two different voltage levels.
 - 1 is represented by the higher voltage level (**HIGH**)
 - 0 is represented by the lower voltage level (**LOW**)

Digital Abstraction

- Q: So, what does “digital” mean anyway?
- A: For now, “digital” means a binary system
 - Only 2 recognized values
 - Low or High
 - 0 or 1
 - Negated or asserted
 - False or True
 - Off or On

Logic Level

- Information in circuits are represented by voltage values.
- The voltages used to represent a 1 and a 0 are called **logic levels**.
- In a practical digital circuit a HIGH can be any voltage between a specified minimum value and a specified maximum value.
- Likewise, a LOW can be any voltage between a specified minimum and a specified maximum.
- There can be no overlap between the accepted range of HIGH levels and the accepted range of LOW levels.

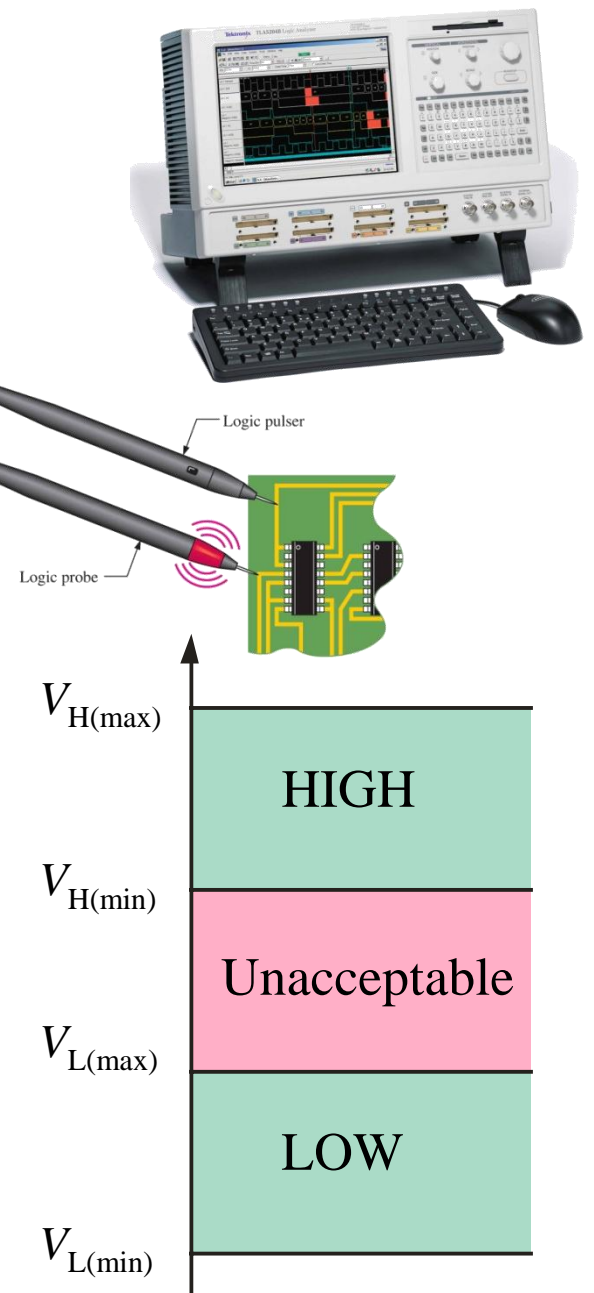

Digital Circuits

ECS 371

Dr. Prapun Suksompong

prapun@siit.tu.ac.th

Lecture 2

Office Hours:

BKD 3601-7

Monday 1:30-3:30

Tuesday 10:30-11:30

ECS371.PRAPUN.COM

Announcement

- **The fact that I will end the class on time does NOT mean that I will leave the room immediately after the lecture.**
 - I will stay to answer questions.
- **Reading Assignment:**
 - Chapter 1: 1-1, 1-2
 - Chapter 2: 2-1, 2-2, 2-3
 - Skip 2.4
 - Chapter 2: 2-5, 2-6
 - Skip 2-7 to 2-12
 - Chapter 3: ALL

Previously on ECS 371

- Digital vs. Analog quantity
- Advantages of digital system
- Digitization: Conversion from analog to digital representation
 - Sampling
 - Quantization
- Digital system = binary system
 - Only 2 recognized values
 - Low or High
 - 0 or 1

Digital Waveforms

- **Digital waveforms** consist of voltage levels that are changing back and forth between the HIGH and LOW levels or states.
- These waveforms represent sequences of bits which contains binary information.
- Each bit in a sequence occupies a defined time interval called a **bit time**.

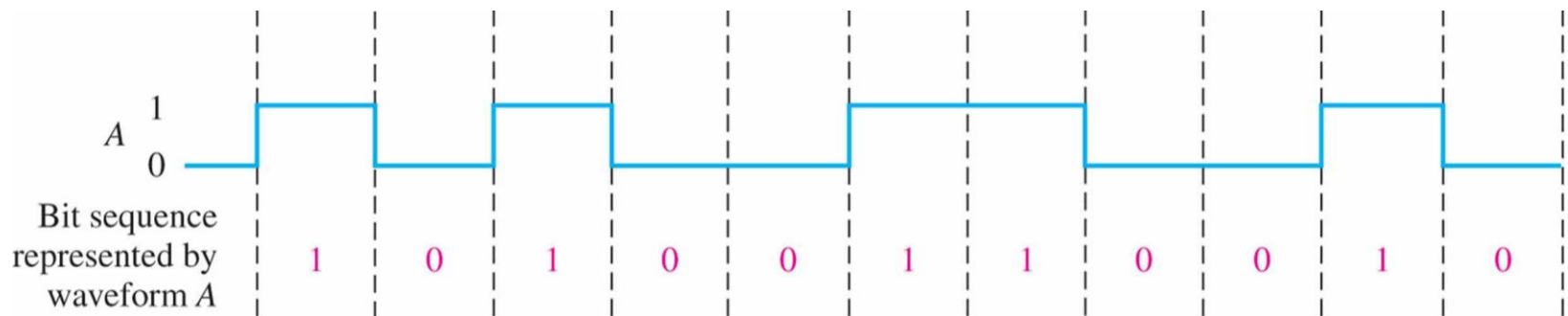

- A group of several bits can be used as a piece of binary information, such as a number or a letter.

Clock Waveform

- In digital systems, all waveforms are synchronized with a clock.
 - The clock waveform itself does not carry information.
- The clock is a periodic waveform in which each interval between pulses (the period) equals the time for one bit.

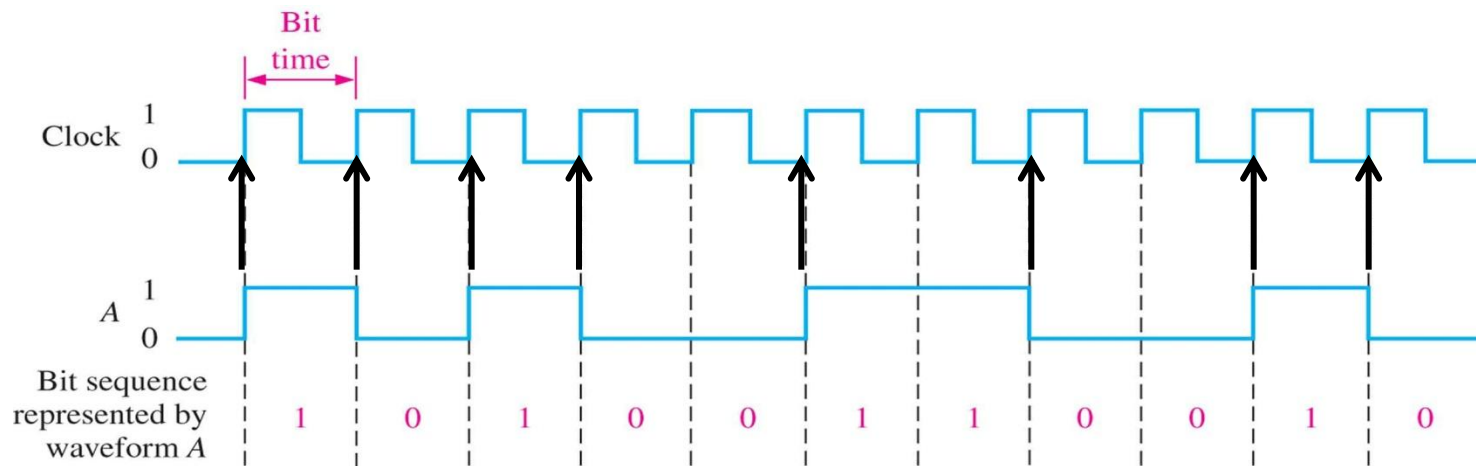

- Notice that change in level of waveform *A* occurs at the leading edge of the clock waveform.

Timing Diagram

- A **timing diagram** is a graph of digital waveforms showing the actual time relationship of two or more waveforms and how each waveform changes in relation to the others.

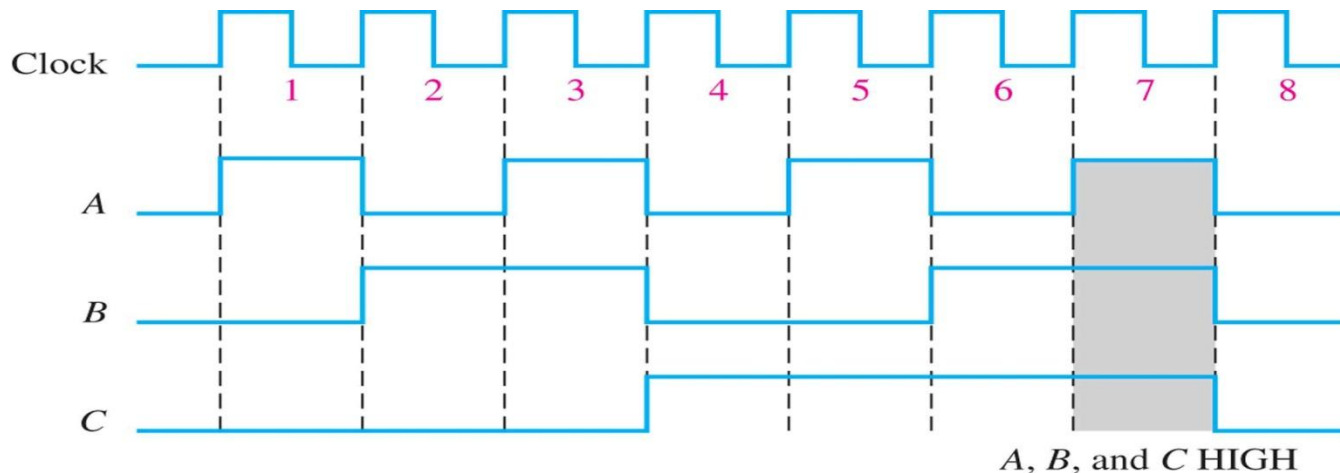

- By looking at a timing diagram, you can determine
 - the states (HIGH or LOW) of all the waveforms at any specified point in time and
 - the exact time that a waveform changes state relative to the other waveforms.

Basic Logical Operation

- What can you do with 0 and 1?
- Basic Building Blocks:

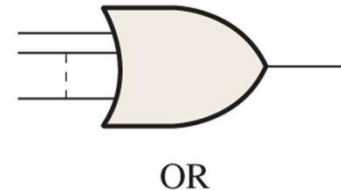
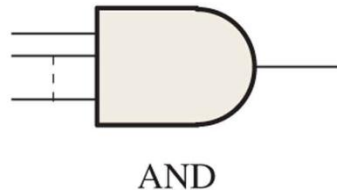
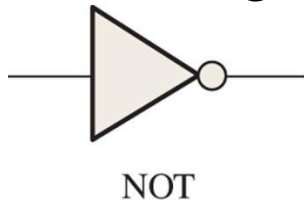

- The NOT operation

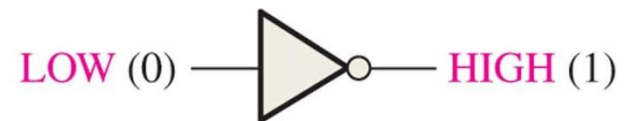
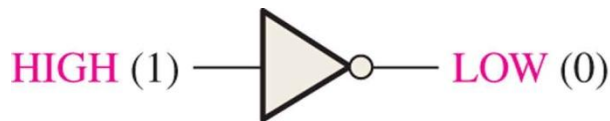

The NOT operation changes one logic level to the opposite logic level.

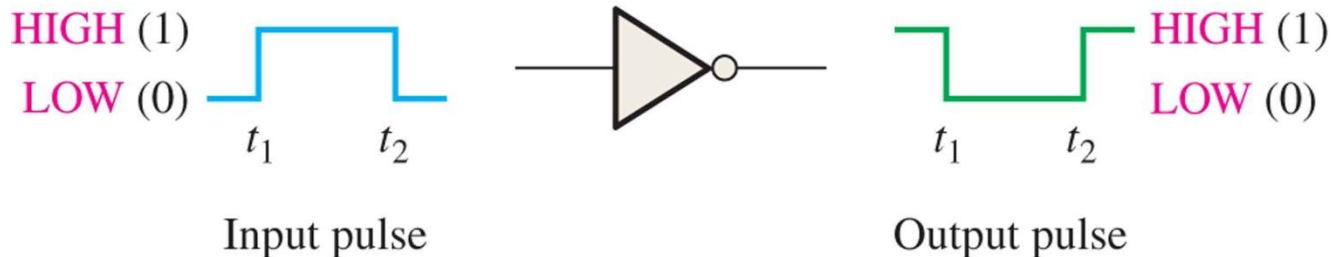

Basic Logical Operation

- The AND operation



Produce a HIGH output only when all the inputs are HIGH.

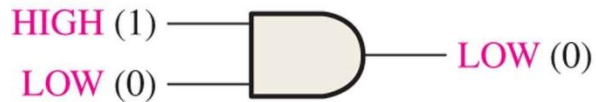

- The OR operation



Produce a HIGH output when one or more inputs are HIGH.



Summary: Truth Table

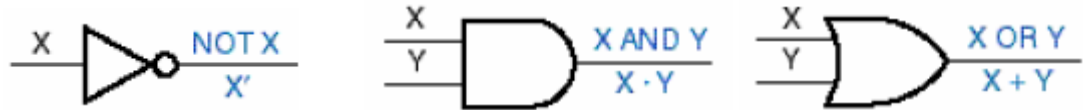

X	Y	NOT X	X AND Y	X OR Y
0	0	1	0	0
0	1	1	0	1
1	0	0	0	1
1	1	0	1	1

Decimal Number System

- The decimal system with its ten digits is a **base-ten** system
- You use decimal numbers every day.
- Each of the ten digits (symbols), 0 through 9, represents a certain quantity.
- The position of each digit in a **weighted** number system is assigned a weight based on the **base** or **radix** of the system.
 - The radix of decimal numbers is ten.
 - The weights for whole numbers are positive powers of ten that increase from right to left, beginning with $10^0 = 1$:

Decimal Number System

- **Example:** Express the decimal number 47 as a sum of the *values* of each digit.

$$47 = (4 \times 10^1) + (7 \times 10^0) = 40 + 7$$

- **Example:** What weight does the digit 7 have in each of the following numbers?

(a) 1370

(b) 6725

(c) 7051

- **Example:** Express each of the following decimal numbers as a sum of the products obtained by multiplying each digit by its appropriate weight

(a) $51 = (5 \times 10) + (1 \times 1)$

(b) $137 = (1 \times 100) + (3 \times 10) + (7 \times 1)$

Binary Number System

- The binary system with its two digits is a base-two system.
 - The two binary digits (bits) are 1 and 0.
- The position of a 1 or 0 in a binary number indicates its weight or value within the number.
- The weight structure of a binary number is

$$2^{n-1} \dots 2^3 2^2 2^1 2^0$$

- The weights increase from right to left by a power of two for each bit.
- The right-most bit is the **LSB (least significant bit)** in a binary whole number and has a weight of $2^0 = 1$.
- The left-most bit is the **MSB (most significant bit)**; its weight depends on the size of the binary number.

Binary Number System

- **Example:** Determine the weight of the 1 in the binary number 10000.

2^0	2^1	2^2	2^3	2^4	2^5	2^6	2^7	2^8
1	2	4	8	16	32	64	128	256

Binary-to-Decimal Conversion

- Add the column values of all of the bits that are 1 and discarding all of the bits that are 0.
- **Example:** Convert the binary whole number 1101101 to decimal.
- **Example:** What is the largest decimal number that can be represented in binary with seven bits?
 - The largest decimal number that can be represented in binary with n bits is $2^n - 1$.

Decimal-to-Binary Conversion

- Two methods
 1. Sum-of-Weights Method
 2. Repeated Division-by-2 Method
- **Sum-of-Weights Method**: determine the set of binary weights whose sum is equal to the decimal number.
- **Example**: Convert the following decimal numbers to binary:
 1. 12
 2. 25
 3. 58

2^0	2^1	2^2	2^3	2^4	2^5	2^6	2^7	2^8
1	2	4	8	16	32	64	128	256

Decimal-to-Binary Conversion

- **Repeated Division-by-2 Method:**
 - The remainders form the binary number.
 - The first remainder to be produced is the LSB.
- **Example:** Convert the following decimal number to binary.
 - (a) 12
 - (b) 45