

COURSE	: ECS 210 Basic Electrical Engineering Lab
INSTRUCTOR	: Dr. Prapun Suksompong (prapun@siit.tu.ac.th)
WEB SITE	: http://www2.siit.tu.ac.th/prapun/ecs210/
EXPERIMENT	: 06 Diodes and Rectifiers

I. OBJECTIVES

1. To study diodes and their applications to half-wave and full-wave rectifiers.
2. To study the use a capacitor as a low-pass filter in a rectifier circuit.

II. BASIC INFORMATION

II.1 Junction Diode

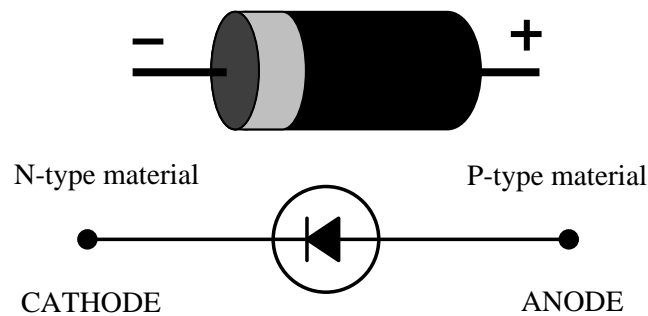

Figure 6-1: Circuit symbol for a semiconductor diode

1. A **junction diode** shown in Figure 6-1 has unidirectional current characteristics; that is, it will permit current to flow through in one direction (when forward-biased), but not the other (reverse-biased). Connection with the negative battery terminal to the N-type and the positive battery terminal to the P-type silicon is called **forward bias**, and results in a flow of current. Connection with the negative battery terminal to the P-type and the positive battery terminal to the N-type is called **reverse bias**. The “turn-on” or “threshold” voltage is 0.7 V for a silicon junction diode and 0.3 V for a germanium diode.

Once this potential is applied across the diode, it will conduct appreciably. Increasing in forward bias voltage causes an increase in the current through the diode.

2. A junction diode can be tested using an ohmmeter. The meter reads the current that the device allows as determined by the voltage applied from the meter. By the Ohm's law, the current reading is then translated into a resistance measurement. When the ohmmeter leads are connected to the diode such that it is forward-biased, high current flows, indicating a low resistance. Reversing the ohmmeter leads causes reverse-biasing to the diode. This prevents the current flow, and thus gives a high resistance reading.
3. The nonlinear characteristic of an ideal diode is illustrated in Figure 6-2. When the source voltage v_i is positive, i_D is positive and the ideal diode becomes a short circuit ($V_D = 0$). When v_i is negative, i_D is zero and the ideal diode becomes an open circuit ($v_D = v_i$). The diode can be thought of as a switch controlled by the polarity of the source voltage. The switch is closed for positive source voltages and open for negative source voltages. In practice, however, V_D is not 0 but $V_D = 0.7$ V for a silicon diode.

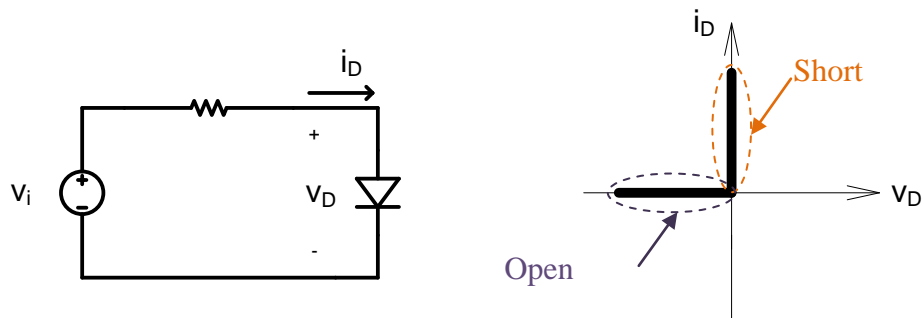

Figure 6-2: The ideal diode and v - i characteristic.

II.2 Rectifier

1. **Rectifiers** convert an ac voltage to a dc voltage. Applications of rectifiers are in both low power instrumentations and those involve higher power, such as dc power supplies.

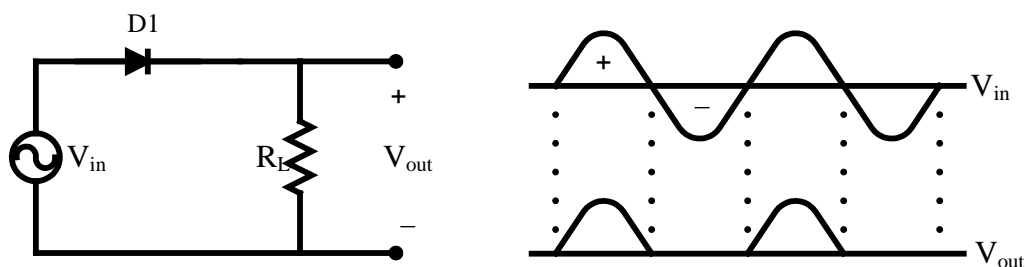

Figure 6-3-1: Diode half-wave rectifier and rectifier waveforms.

2. Figure 6-3-1 shows a **half-wave rectifier** circuit. The output of a half-wave rectifier is positive or zero depending on whether the input is positive or negative, respectively, as shown in Figure 6-3-1.

When the sinusoidal input voltage is positive, the diode is forward biased and therefore the diode conducts. When the sinusoidal input voltage is negative, the diode is reverse biased and no current flow through the diode. The current through the resistor in series with the diode is therefore zero. Hence the voltage across the resistor is zero.

3. For the half-wave rectifier shown in Figure 6-3-1, the average of the input voltage V_{in} is zero. The average value of the output voltage is

$$\frac{1}{2\pi} \int_0^{\pi} A \sin x dx = \frac{A}{\pi}$$

where A is the peak input voltage. For example, if we use $10 V_{rms}$ input voltage, then

$$A \approx 10\sqrt{2} \text{ V},$$

the average value of the output voltage is $\frac{10\sqrt{2}}{\pi} \approx 4.5 \text{ V}$.

These average values can be measured by the DMM in DC mode. In particular, Suppose a periodic signal $x(t)$ with period T is fed into DMM. In DC mode, the DMM will measure the average value which is

$$\frac{1}{T} \int_0^T x(t) dt$$

Remark: It is useful to remember that

the average of $\sin x$ is 0, the average of $\sin^2 x$ is $1/2$, and the average of $|\sin x|$ is $2/\pi$.

4. In this experiment, the input of the half-wave rectifier is a 236/(10-0-10) center-tapped transformer as shown in Figure 6-3-2.
5. Figure 6-3-3 shows a **full-wave rectifier** using two diodes. The direction of the current flowing in the load resistor produces the positive output voltage, in both positive and negative input voltage.
6. Figure 6-3-4 shows a **full-wave bridge rectifier** using four diodes.

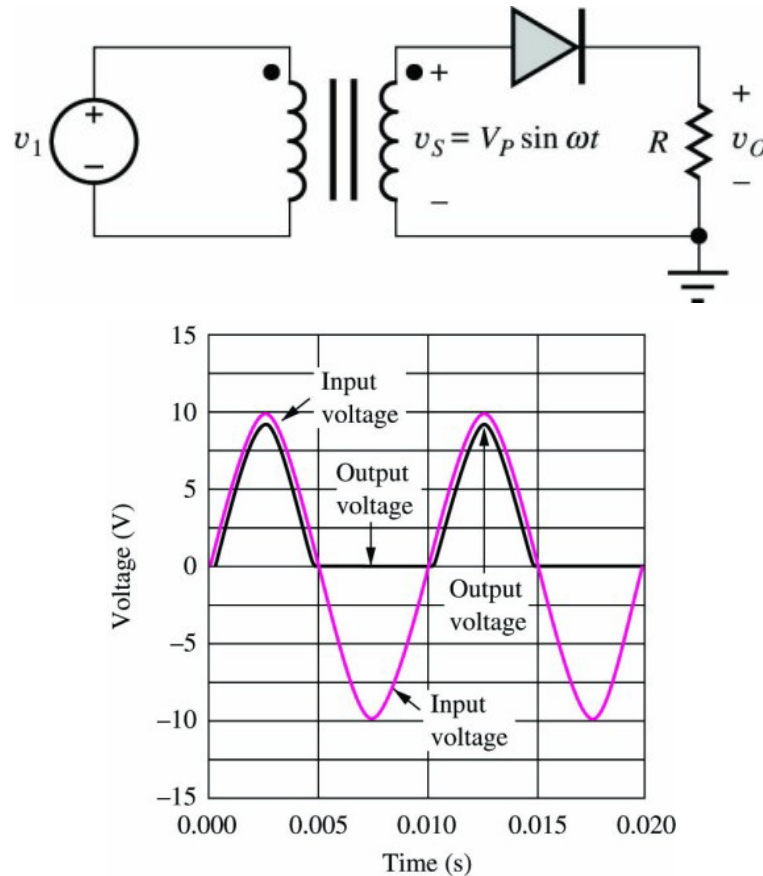

Figure 6-3-2: A half-wave rectifier and its output waveforms when the input is a 236/(10-0-10) center-tapped transformer

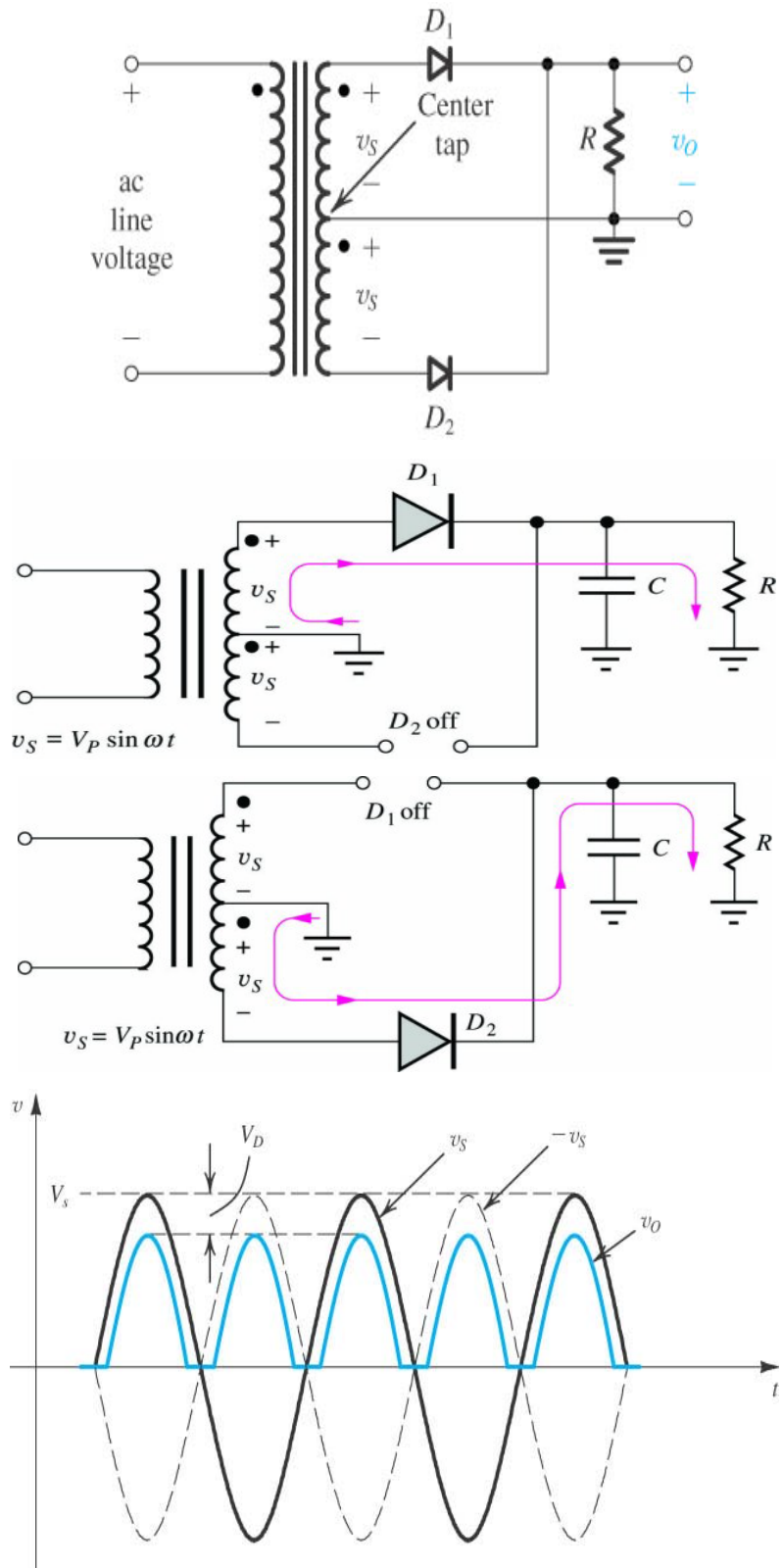

Figure 6-3-3: A full-wave rectifier and its output waveforms.

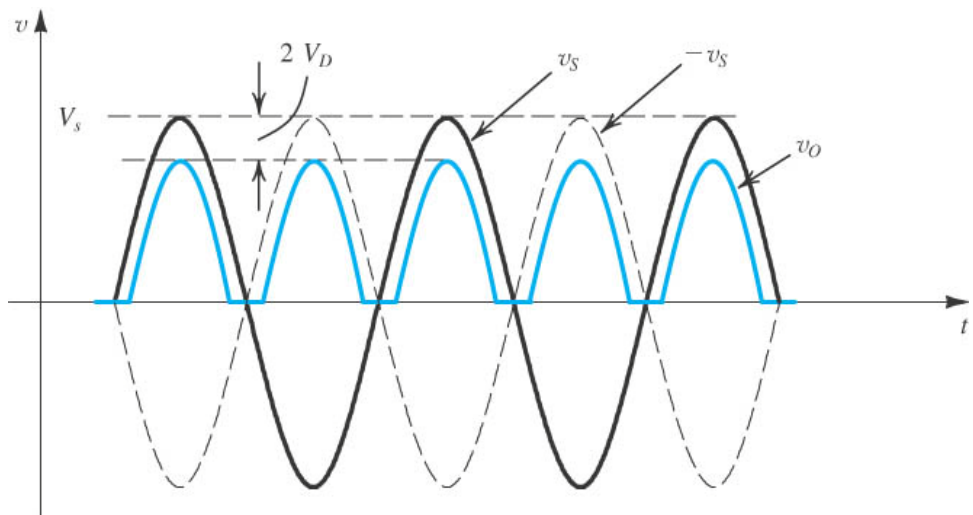
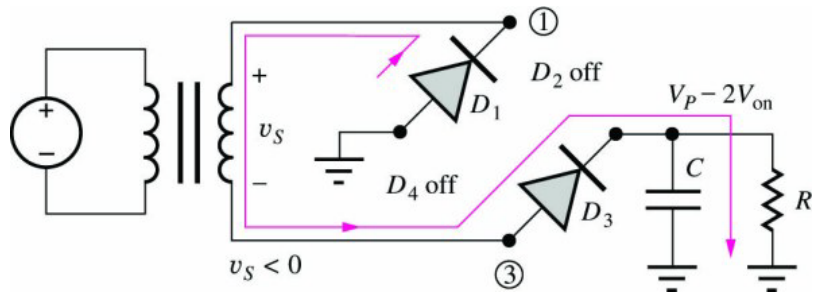
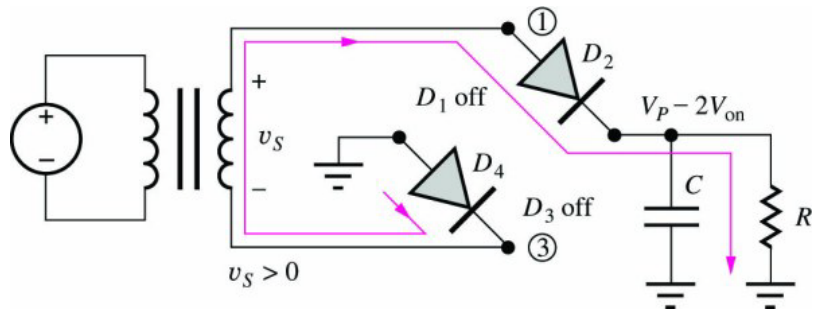
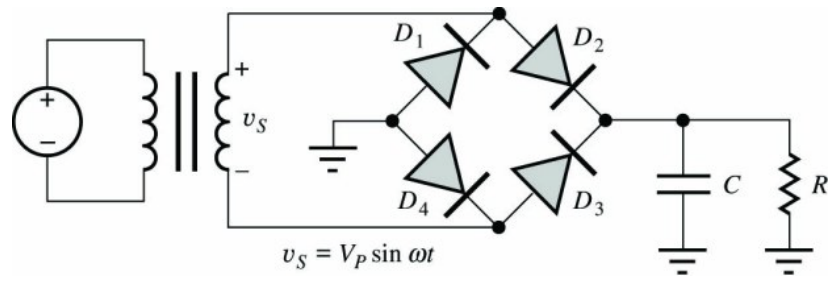

Figure 6-3-4: A full-wave bridge rectifier and its output waveforms.

7. The output of the rectifier contains considerable voltage variation called a **ripple**. A low-pass filter is usually required to remove the ripple. The simplest low-pass filter can be constructed using a **large capacitor** connected across the output of the rectifier, in parallel with the load resistor as shown in Figures 6-3-3 and 6-3-4. Figure 6-4 shows the output waveforms with ripples.

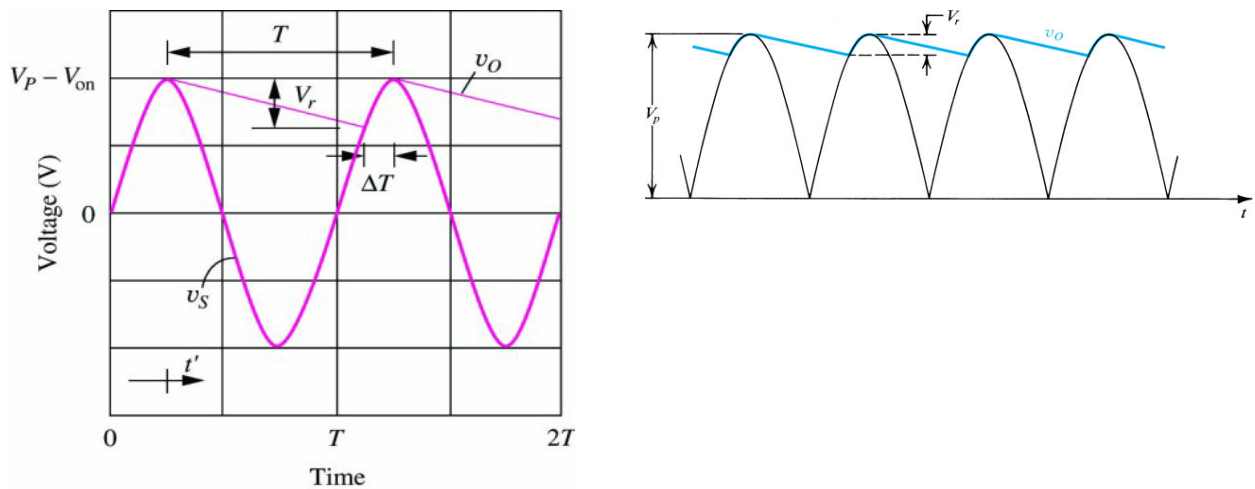

Figure 6-4: Output waveforms with ripples.

8. The polarity of the **electrolytic capacitor** is almost always indicated by a printed band. The lead nearest to that band is the cathode lead (-). Additionally, the positive lead is usually longer.

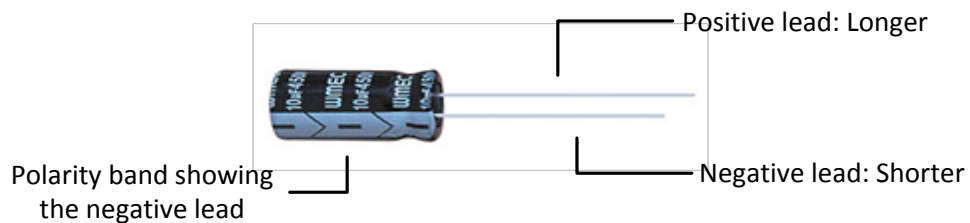

Figure 6-5: Electrolytic Capacitor

Caution: Most electrolytic capacitors are polarized. Hook them up the wrong way and at best, you'll block the signal passing through. At worst (for higher voltage applications) they'll explode.

9. A centre tapped transformer is shown in Figure 6-6. The label '236/(10-0-10)' is represented in **rms** values. This means that the input voltage is approximately 236 Vrms and the outputs are approximately 10Vrms and 10Vrms.

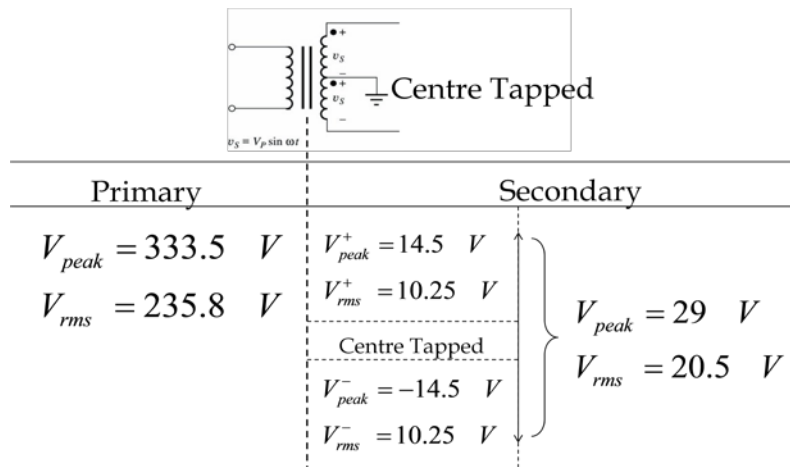

Figure 6-6: A Centre-Tapped Transformer

III. MATERIALS REQUIRED

Power supply: 236-V 50-Hz source

Equipment: Oscilloscope, Multi-meter.

Resistors: 1 k Ω , 2.7 k Ω , 5.6 k Ω , and 10 k Ω .

Capacitors: 100- μ F 50-V

Diodes: Four solid state diodes 1N4001

Power transformer with center tapped secondary, 236/(10-0-10).

IV. PROCEDURE

Warning:

This experiment use high voltage. Great care is needed to avoid direct contact to the transformer. Damage on any equipment, devices, or any part of your body is subject to punishment.

Part A: Half-wave and full-wave rectifiers.

1. Connect a half-wave rectifier circuit shown in Figure 6-7.

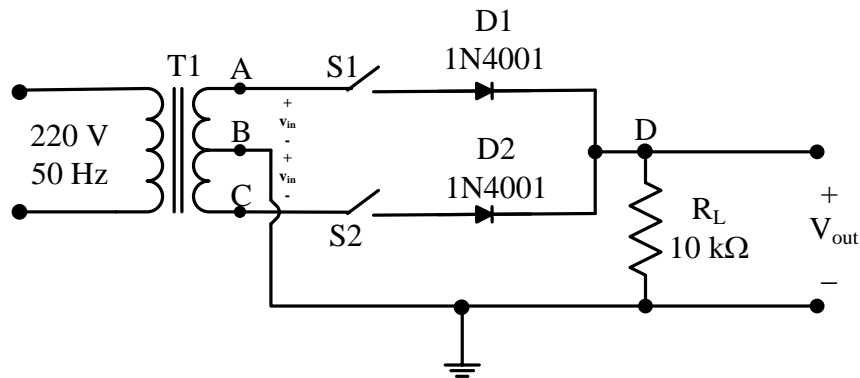

Figure 6-7: A half-wave and full-wave rectifier circuit.

2. Close the switch S1 and open the switch S2. This means that node 'A' is connected to the anode of D1, and node 'C' is not connected to the anode of D2.
3. Use the oscilloscope in DC mode. Measure the peak-to-peak voltage values and observe the waveforms of V_{in} (connect Channel 1 to node 'A' with respect to node 'B') and V_{out} (connect Channel 2 to node 'D' with respect to node 'B'). Record the results in Table 6-1. Do not forget to indicate where the ground level of the voltage is.
Remark: Because B is connected to the ground, $v_C = -v_A$.
4. With a DMM (**in DC mode**), measure and record the DC voltage of V_{in} and V_{out} in Table 6-1.
5. Open S1 and close S2. Then repeat steps 3 and 4.
6. Close S1 and S2. Then repeat steps 3 and 4.

Part B: Effects of a filter capacitor on the output of full-wave rectifier.

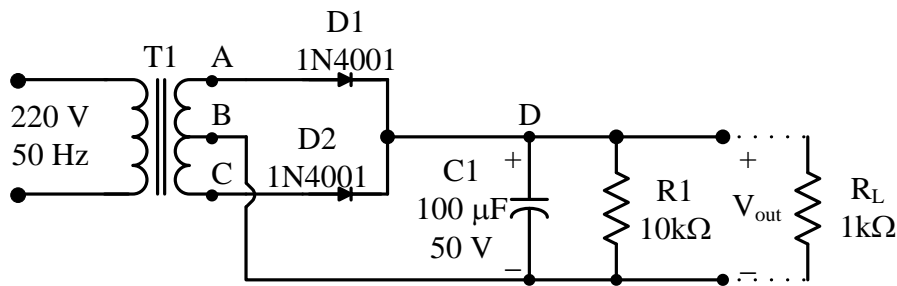

Figure 6-8: A full-wave rectifier with capacitor filter.

1. Connect the circuit of Figure 6-8 **without** the load R_L . Note that the capacitor C_1 has +/- polarity, and its terminals must be connected correctly.
2. Use a voltmeter to measure V_{out} , the dc output voltage across R_1 , and record the result in Table 6-2.
3. Set the oscilloscope in DC mode. Connect Channel 1 to node A with respect to node B and connect Channel 2 to node D with respect to node B.
4. On channel 2, observe, measure, and record **the ripple waveform** and its peak-to-peak voltage in Table 6-2.
5. Connect a 1 kΩ load resistor (R_L).
6. Repeat steps 2 to 4.

Part C: Bridge rectifier.

1. Connect a full-wave bridge rectifier as shown in Figure 6-9. Note that one end of the transformer secondary is open.

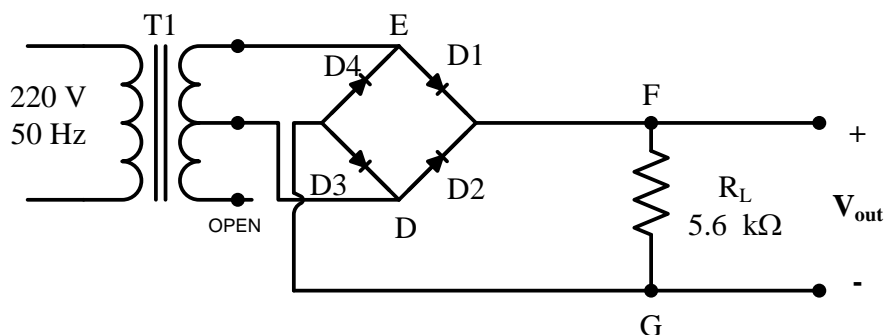

Figure 6-9: A bridge rectifier circuit.

2. Observe and draw the waveform of V_{out} (the output voltage across R_L) in Table 6-3.
3. Switch off the power supply.

TABLE 6-1: Half-wave and full-wave measurements.

Waveform									V _{p-p}	DC (V)
(A.3, A.4)										
V _{in} (A to B)										
close S1										
open S2										
(A.3, A.4)										
V _{out}										
close S1										
open S2										
(A.5)										
V _{in} (A to B)										
close S2										
open S1										
(A.5)										
V _{out}										
close S2										
open S1										
(A.6)										
V _{out} (full-wave)										
close S1										
close S2										

TA's Signature: _____

TABLE 6-2. Capacitive Filter.

Load [Ohms]	Average V_{out} [V]
None	
1K	

Ripple Waveform									Vp-p
No load									
1 k Ω									

TA's Signature: _____

TABLE 6-3. Bridge rectifier output

volts/div = _____

Time/div = _____

TA's Signature: _____

QUESTIONS

- The main use of a diode is
 - To detect RF signals.
 - To convert AC voltage into DC.
 - To regulate voltage.
 - To allow current to flow in just one direction.
 - None of the above.
- The most common materials used to manufacture diodes are:
 - Silicon and Germanium
 - Silicon and Gallium Arsenide
 - Silicon and Selenium
 - Silicon and Cuprous Oxide
 - None of the above.
- Diodes have two terminals, called:
 - Positive and negative
 - Bar and triangle
 - Source and drain
 - Emitter and collector
 - None of the above.
- The typical voltage drop on a silicon diode is of:
 - 0.15 V
 - 0.3 V
 - 0.5 V
 - 0.6 V to 0.7 V
 - None of the above.
- If values of voltage which are shown below measure from DMM, what are the voltages peak across R_1 , D_1 and D_2 ?

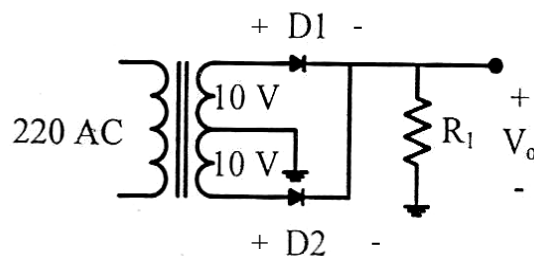

- 10 V, 10 V and 10 V
- 10 V, 20 V and 20 V
- 14.14 V, 14.14V and 14.14V
- 14.14V, 28.28V and 28.28V
- None of the above.