

Sirindhorn International Institute of Technology
Thammasat University at Rangsit
School of Information, Computer and Communication Technology

COURSE	: ECS 210 Basic Electrical Engineering Lab
INSTRUCTOR	: Dr. Prapun Suksompong (prapun@siit.tu.ac.th)
WEB SITE	: http://www2.siiit.tu.ac.th/prapun/ecs210/
EXPERIMENT	: 01 DC Measurements

I. OBJECTIVES

1. To measure dc voltage and current in electrical circuits.
2. To verify Ohm's law.
3. To study voltage-divider and current-divider circuits.
4. To verify Kirchhoff's voltage and current laws.

II. BASIC INFORMATION

1. The amount of current in a circuit depends on the amount of voltage applied to the circuit and the nature of the conductive path. Ammeters and voltmeters are used to measure current and voltage, respectively. Recall from Experiment 00 that, **to measure a current, the ammeter terminals must be connected in series with the current to be measured. In measuring a voltage, the voltmeter terminals must be connected in parallel with the voltage to be measured.** Connecting either an ammeter or a voltmeter into a circuit may disturb the circuit in which the measurement is being made. It is therefore important to be aware of these possible meter-loading effects.
2. The voltage across many types of conducting materials is directly proportional to the current flowing through the material. The constant of the proportionality is called resistance. This fact was discovered by George Simon Ohm, a German physicist, and it is thus referred to as **Ohm's law**. Resistors are one of the most commonly used elements in electric and electronic circuits. Materials often used in fabricating resistors are metallic alloys and carbon compounds.

3. Practical resistors are specified by their nominal resistance value and tolerance value. The most common type of resistors is the carbon composition or carbon film resistor. Resistors are limited in their ability to dissipate heat. Their **power ratings** commercially available are 1/8, 1/4, 1/2, 1, and 2 W. Since heat-dissipation capability is related to the surface area, resistors with larger power ratings are physically larger than those with smaller ratings. Ohmmeters are used to measure resistance. It should be noted that **the resistor must not be connected to any circuit at the time its resistance is being measured by an ohmmeter. Otherwise, the resistance value read by the ohmmeter will be incorrect.**
4. By definition, an electric circuit is an interconnection of electrical elements. The interconnection of the elements, however, imposes constraints on the relationships between the terminal voltages and currents. The two laws that state the constraints in mathematical form are known as **Kirchhoff's current law (KCL)** and **Kirchhoff's voltage law (KVL)**. These two laws are named after Gustav Kirchhoff, a German physicist, and can be stated as follows.
 - KCL: For any electric circuits, the algebraic sum of all branch currents at any node is zero.
 - KVL: For any electric circuits, the algebraic sum of all voltages around any loop is zero.
5. Ohm's law and Kirchhoff's laws find immediate applications in designing **voltage-divider and current-divider circuits**. A simple voltage-divider circuit consists of two resistors connected in series with a voltage source. The voltage divides between the two resistors in series such that the voltage across either resistor equals the source voltage multiplied by the resistance of that resistor and divided by the sum of the resistances. A simple current-divider circuit, on the other hand, consists of two resistors connected in parallel across a current source. The current divides between two resistors in parallel such that the current in either resistor equals the source current multiplied by the resistance of the other branch and divided by the sum of the resistances.

We now elaborate the concepts mentioned above.

II.1 Ohm's law

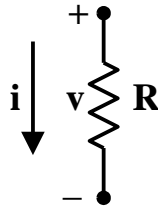

Figure 1-1: The representation of voltage and current of a resistor.

Ohm's law states that the voltage (v) across and current (i) through a resistor (R) as shown in Figure 1-1 can be represented by

$$v = i R,$$

where v is the voltage across the resistor in volts, i is the current flowing through the resistor in amperes, and R is the resistance in ohms.

II.2. Kirchhoff's current law (KCL)

For any electric circuits, the algebraic sum of all branch currents at any node is zero. Let's consider the circuit in Figure 1-2. The total current I_T flows from the source *into* node A. At this node, the current splits into three branches as indicated in the figure. Each of the three branch currents, I_1 , I_2 , and I_3 , flows *out* of node A. KCL states that the total current into node A is equal to the total current out node A, that is,

$$I_T = I_1 + I_2 + I_3$$

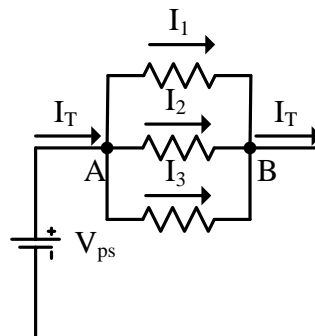

Figure 1-2: Total current into node A is equal to the sum of currents out of node A. The sum of currents into node B equals the total current out of node B.

Following the currents through the three branches, we can see that they come back together at node B, where the current I_T flows out. KCL applied at this node, therefore, gives the same equation as that at node A.

II.3 Kirchhoff's voltage law (KVL)

For any electric circuits, the algebraic sum of the branch voltages around any loop is zero. For example, in the circuit shown in Figure 1-3, there are three voltage drops (denoted by V_1 , V_2 , and V_3) and one voltage source (V_s). By KVL, we can algebraically sum all of the voltages around the circuit to obtain

$$V_1 + V_2 + V_3 - V_s = 0$$

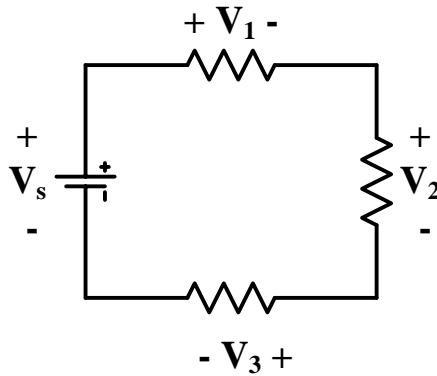

Figure 1-3: The sum of the voltage drops equals the source voltage, V_s .

Alternatively, the above equation can be expressed by moving the voltage drop terms to the right side of the equation, i.e.

$$V_s = V_1 + V_2 + V_3$$

In other words, the source voltage is equal to the sum of all voltage drops.

II.4. Voltage-divider circuit

Figure 1-4 shows an example of a voltage divider circuit. Applying KVL around the closed loop yields

$$V_s = i(R_1 + R_2),$$

which implies

$$i = \frac{V_s}{(R_1 + R_2)}$$

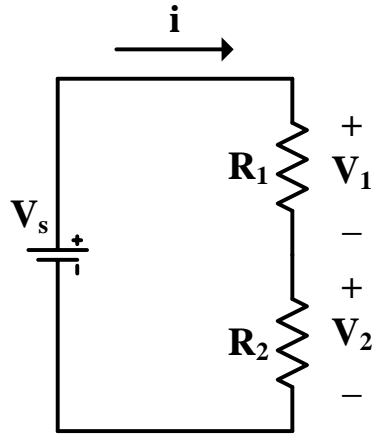

Figure 1-4: The voltage-divider circuit.

By using the Ohm's law, V_1 can be found, i.e.

$$V_1 = iR_1 = \frac{V_s}{(R_1 + R_2)} R_1$$

Observe that V_1 is a fraction of V_s , where the fraction is equal to the ratio of R_1 to $R_1 + R_2$.

Similarly, V_2 can be found via

$$V_2 = iR_2 = \frac{V_s}{(R_1 + R_2)} R_2.$$

II.5. The current-divider circuit

An example of a current-divider circuit is shown in Figure 1-5. It consists of two resistors connected in parallel across a current source. The source current i_s in Figure 1-5 is divided between into two branches.

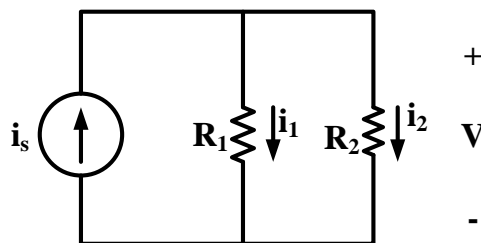

Figure 1-5: The current-divider circuit.

We find the relationship between i_s and the current through each resistor (i_1 and i_2) by directly applying Ohm's law and KCL. First, the voltage across the parallel resistors is

$$v = i_1 R_1 = i_2 R_2$$

By KCL, $i_s = i_1 + i_2$. Therefore

$$i_s = \frac{v}{R_1} + \frac{v}{R_2} = v \left(\frac{1}{R_1} + \frac{1}{R_2} \right),$$

which gives

$$v = \frac{i_s}{\frac{1}{R_1} + \frac{1}{R_2}}$$

Thus, we have

$$i_1 = \frac{v}{R_1} = i_s \frac{\frac{1}{R_1}}{\frac{1}{R_1} + \frac{1}{R_2}} = i_s \frac{R_2}{(R_1 + R_2)}$$
$$i_2 = \frac{v}{R_2} = i_s \frac{\frac{1}{R_2}}{\frac{1}{R_1} + \frac{1}{R_2}} = i_s \frac{R_1}{(R_1 + R_2)}.$$

III. MATERIALS REQUIRED

- DC power supply
- Multi-meter
- Resistors (1/2-W):
330- Ω , 470- Ω , 820- Ω , 1-k Ω , 1.2-k Ω , 2-k Ω , 2.2-k Ω , 3.3-k Ω , 4.7-k Ω , and 10-k Ω .

IV. PROCEDURE

When you finish each part of the experiment, make sure that both you and your lab partner have completed the corresponding table. You will need signature from the TAs or the lab instructor for each part of the experiment. The signatures are required for both your sheet and your lab partner sheet. Include these sheets in the lab report.

Part A: Verification of Ohm's law

1. Turn on the dc power supply.
2. Use a DMM to measure the output voltage (V_{ps}) of the power supply, and adjust the voltage until the meter reads 10 V. Note that getting exactly 10.00 is not easy. Try to get as close to 10.00 as possible. Record the exact (measured) value of the voltage in Table 1-1.
3. Measure the resistance of a resistor $R = 2\text{ k}\Omega$, and record the result in Table 1-1.
4. Connect the circuit as in Figure 1-6. Measure the current I flowing through the resistor, and record the result in Table 1-1.

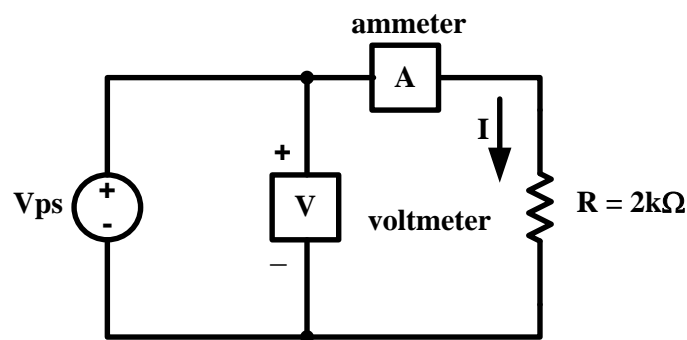

Figure 1-6: The circuit for verifying Ohm's law.

5. Vary V_{ps} to 15 V, 20 V, and 25V. Record the actual output voltage from the power supply and the corresponding currents in Table 1-1.
6. Calculate the value of I in each of the above cases, and record the results in Table 1-1.

Part B: Voltage-divider circuit

1. Use $R_1 = 10\text{ k}\Omega$ and $R_2 = 2\text{ k}\Omega$. Measure the resistance of R_1 and R_2 , and record the results in Table 1-2.
2. Turn on the power supply.
3. Connect a voltmeter across the power supply, and adjust the output voltage V_{ps} of the supply so that $V_{ps} = 12\text{V}$.
4. Connect the circuit in Figure 1-7.

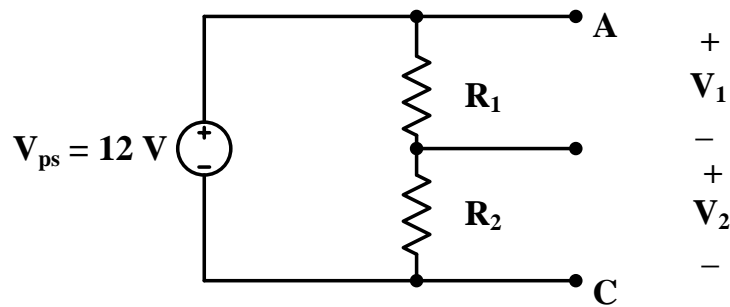

Figure 1-7: A voltage-divider circuit.

5. Measure the voltage across R_1 ; this is the voltage V_1 in the figure. Record the result in “measured value” of V_1 in Table 1-2.
6. Similarly, measure V_2 in the figure, and record the value in “measured value” of V_2 in Table 1-2.
7. Use the **measured** values of V_{ps} , R_1 , and R_2 to calculate V_1 and V_2 by voltage-divider rules:

$$V_1 = V_{ps} \cdot \frac{R_1}{R_T}$$

$$V_2 = V_{ps} \cdot \frac{R_2}{R_T}$$

where R_T is the total resistance $R_1 + R_2$. Record the values in "calculated value" in Table 1-2.

Part C: Current-divider circuit

1. Let $R_1 = 2.2 \text{ k}\Omega$, $R_2 = 3.3 \text{ k}\Omega$, and $R_3 = 4.7 \text{ k}\Omega$. Measure the resistance of each resistor, and record the values in Table 1-3.
2. Turn on the power supply, and adjust the supply so that the output voltage $V_{ps} = 15 \text{ V}$.
3. Connect the circuit as in Figure 1-8. The figure also shows how to connect the ammeter and voltmeter to measure V_{ps} , I_T , I_1 , I_2 , and I_3 . Because you have only one DMM, you can only measure the values one at a time.

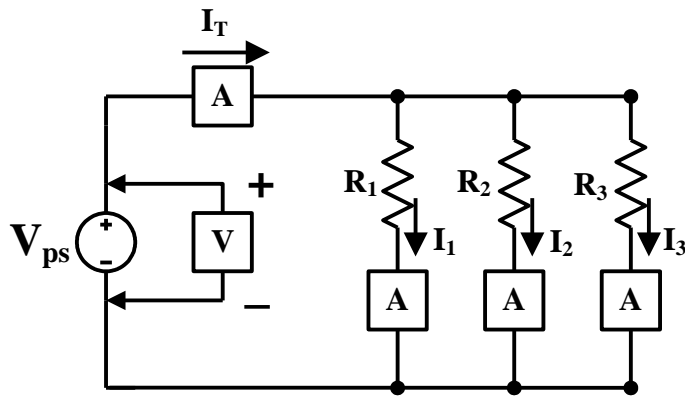

Figure 1-8: A current-divider circuit.

4. Measure I_T , I_1 , I_2 , and I_3 using the DMM. Record the values in Table 1-3.
5. Calculate I_1 , I_2 , and I_3 by current-divider rules:

$$I_1 = I_T R_T / R_1$$

$$I_2 = I_T R_T / R_2$$

$$I_3 = I_T R_T / R_3$$

$$I_T = V_{ps} / R_T$$

where R_T is the total resistance $R_1 // R_2 // R_3$. Record the results in “calculated value” in Table 1-3. Use the measured values of I_T , R_1 , R_2 , and R_3 in your calculation.

6. Calculate the value of I_T again by adding the calculated values of I_1 , I_2 , and I_3 . Record the values in Table 1-3. This should be exactly equal to the measured value of I_T that you have recorded before.

Part D: Verification of Kirchhoff's laws

1. Turn on the dc power supply, and adjust the supply so that the output voltage $V_{ps} = 15\text{ V}$. Record this value in V_{ps} (measured) in Table 1-4.
2. Measure and record the resistance values of all resistors. Connect the circuit shown in Figure 1-9.

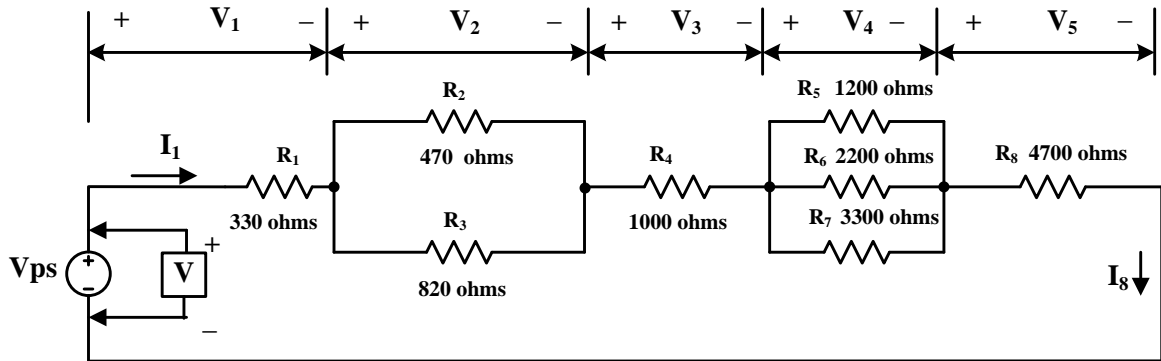

Figure 1-9: The circuit for verifying Kirchhoff's laws.

3. Measure the voltages V_1 , V_2 , V_3 , V_4 , and V_5 , and record the values in Table 1-4.
4. Calculate V_{ps} ($= V_1 + V_2 + V_3 + V_4 + V_5$), and record the result in V_{ps} (calculated) in Table 1-4. Use the measured values of V_1 , V_2 , ..., V_5 in your calculation.
5. Measure I_1 , which is the current flowing through R_1 , and record the value in Table 1-4.
6. Measure the currents I_2 , I_3 , I_4 , I_5 , I_6 , I_7 , and I_8 , which are currents flowing through R_2 , R_3 , R_4 , R_5 , R_6 , R_7 , and R_8 , respectively. Record the values in Table 1-4.
7. Turn off the power supply.
8. Calculate the sum of I_2 and I_3 , and record the result in the table. Check your result by comparing the value with I_4 .
9. Calculate the sum of I_5 , I_6 , and I_7 , and record the values in Table 1-4. Check your result by comparing it with I_8 .
10. Calculate V_1 , V_2 , V_3 , V_4 , and V_5 by using Ohm's law (e.g., $V_1 = I_1 R_1$), and record your results in Table 1-4.

TABLE 1-1: Verification of Ohm's law

	R = _____			
V (volts)	10	15	20	25
I (amps)				
Calculated I (amps)				

TA Signature:

TABLE 1-2: Voltage-divider circuit

$R_1 =$ _____ $R_2 =$ _____

	V_{ps}	V_1	V_2
Measured value			
Calculated value	N/A		

TA Signature:

TABLE 1-3: Current-divider circuit

$R_1 =$ _____ $R_2 =$ _____ $R_3 =$ _____

	V_{ps}	I_1	I_2	I_3	I_T
Measured value					
Calculated value	N/A				

TA Signature:

TABLE 1-4: Verification of Kirchhoff's laws

$V_{PS} =$ _____ (measured). $V_{PS} =$ _____ (calculated in part D.4).

- $R_1 =$
 $R_2 =$
 $R_3 =$
 $R_4 =$
 $R_5 =$
 $R_6 =$
 $R_7 =$

Measured value					Calculated value				
V_1	V_2	V_3	V_4	V_5	V_1	V_2	V_3	V_4	V_5
Measured value							Calculated value		
I_1	I_2	I_3	I_4	I_5	I_6	I_7	I_8	$I_2 + I_3$	$I_5 + I_6 + I_7$

TA Signature:

QUESTIONS:

Choose a correct answer for each question.

1. When an additional resistor is connected across an existing parallel connection of resistors, the total resistance _____.
(a) decreases. (b) increases.
(c) remains the same. (d) increases by the value of the added resistor.
2. In a series connection of resistors, each resistor has _____.
(a) the same current. (b) the same voltage.
(c) the same power. (d) all of the above.

Fill in the blanks with a correct answer.

1. Loop equations are written by applying _____ to each loop in a circuit.
2. When a $1.2\text{ k}\Omega$ resistor and a $2100\ \Omega$ resistor are connected in parallel, the total resistance is _____. When they are connected in series, the total resistance is _____.
3. A good ammeter should have _____ (value) internal resistance.
4. To calculate the current flowing through a resistor, a voltmeter is connected in _____ with that resistor, and the relationship between the measured voltage and _____ can be used to determine the current value.
5. A good voltmeter should have _____ (value) internal resistance.

True or False.

1. _____ A constant voltage is provided by a constant current source across its terminals under all load conditions.
2. _____ The total resistance of a parallel connection of R_1 and R_2 is greater than $R_1 + R_2$.

Analyze the circuit.

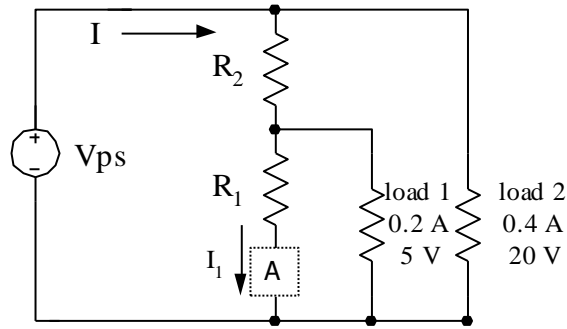

Figure 1-10: The circuit used in the analysis.

A voltage-divider circuit in Figure 1-10, with $V_{ps} = 20\text{ V}$, can supply two loads: load 1 is 0.2 A at 5 V, and load 2 is 0.4 A at 20 V. Assume that the current I_1 is 0.1 A. The value of R_1 and R_2 must be

$$R_1 = \text{_____ } \Omega, \quad R_2 = \text{_____ } \Omega.$$

The resistance of each load is:

$$\text{load 1's resistance} = \text{_____ } \Omega, \quad \text{load 2's resistance} = \text{_____ } \Omega.$$

The current $I = \text{_____ } \text{A}$.

Show the detail of your analysis in the report.