

COURSE	: ECS 204 Basic Electrical Engineering Lab
INSTRUCTOR	: Asst. Prof. Dr. Prapun Suksompong (prapun@siit.tu.ac.th)
WEB SITE	: http://www2.siit.tu.ac.th/prapun/ecs204/
EXPERIMENT	: 05 RC Circuit and Resonant RLC Circuit

I. OBJECTIVES

1. To investigate RC circuit with voltage step input.
2. To determine the resonant frequency and frequency response of a series RLC circuit.

II. BASIC INFORMATION

II.1 RC Circuit with Voltage Step Input

1. An RC circuit with voltage step input is shown in Figure 5-1-1. From KCL, we have

$$C \frac{d}{dt} v_{out}(t) + \frac{v_{out}(t) - v_{in}(t)}{R} = 0$$

If the input voltage $v_{in}(t)$ is fixed at a particular value V_S from time t_1 to t_2 , then the output voltage $v_{out}(t)$ during this time interval is given by

$$v_{out}(t) = V_S + (v_{out}(t_1) - V_S) e^{-\frac{t-t_1}{\tau}}, \quad t_1 \leq t \leq t_2, \quad (1)$$

where $v_{out}(t_1)$ is the initial output voltage (for this interval which starts at time t_1) and $\tau = RC$ is the time constant.

In Part A of this experiment, the input voltage $v_{in}(t)$ is a square-wave; $v_{in}(t)$ will be 0 or 4 V.

2. For simplicity, assume $t_1 = 0$. Then, the output voltage is given by

$$v_{out}(t) = V_S + (v_{out}(0) - V_S)e^{-\frac{t}{\tau}}.$$

Now, further assume that $v_{out}(0) = 0$. Then

$$v_{out}(t) = V_S - V_S e^{-\frac{t}{\tau}} = V_S \left(1 - e^{-\frac{t}{\tau}}\right).$$

Therefore, the voltage across the capacitor increases from 0 to V_S and we say that the capacitor is **charging**. Note that in one time constant ($t = \tau$), the capacitor is charged to approximately $V_S(1 - e^{-1}) \approx 0.63V_S$, i.e. the voltage across the capacitor becomes approximately 63 percent of V_S .

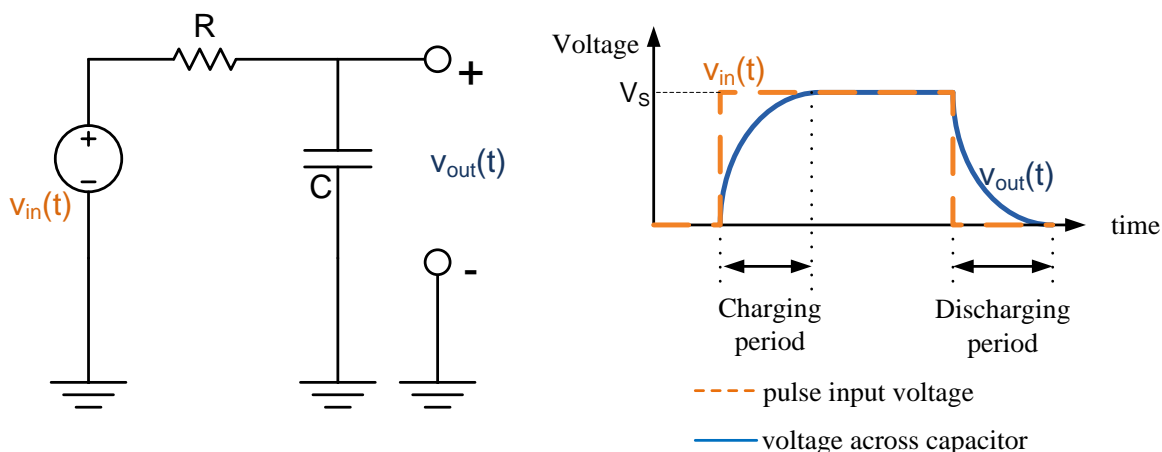

Figure 5-1-1: Pulse input voltage and the voltage across a capacitor.

3. When the input voltage $v_{in}(t)$ is fixed at 0 from time t_1 to t_2 , the solution (1) above gives

$$v_{out}(t) = 0 + (v_{out}(t_1) - 0)e^{-\frac{t-t_1}{\tau}} = v_{out}(t_1)e^{-\frac{t-t_1}{\tau}}, \quad t_1 \leq t \leq t_2,$$

For simplicity, assume that $t_1 = 0$ and that the initial output voltage $v_{out}(t_1) = V_0$. Then,

$$v_{out}(t) = V_0 e^{-\frac{t}{\tau}}.$$

Therefore, the voltage across the capacitor decreases from V_0 to 0 and we say that the capacitor is **discharging**. In one time constant ($t = \tau$), the capacitor is discharged to approximately $V_0 e^{-\frac{\tau}{\tau}} = \frac{V_0}{e} \approx 0.37V_0$, or 37 % of the initial voltage V_0 .

4. **Half Life.** The half life t_{half} is the time t that is needed for the output voltage of a discharging capacitor to decrease from V_0 to $V_0/2$. At such time,

$$\frac{V_0}{2} = V_0 e^{-\frac{t}{\tau}}.$$

Solving for t in the above equation gives

$$t_{half} = \tau \ln 2.$$

5. In part A of this experiment, the value of τ are found using three different methods (see Figure 5-1-2):

- 1) Measure $t_{0.37}$. Then, $\tau = t_{0.37}$.
- 2) Measure t_{half} . Then, calculate $\tau = t_{half} / \ln 2$.
- 3) Measure R and C. Then, calculate $\tau = RC$.

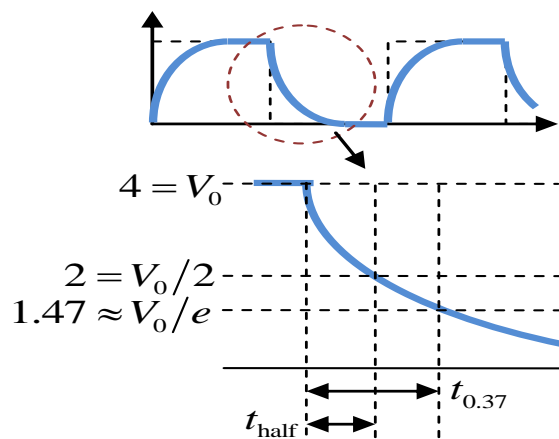

Figure 5-1-2: τ measurement.

II.2 Series RLC Circuit

1. Resistors limit the amount of current in dc as well as in ac circuits. In addition to resistors, reactive components, such as inductors and capacitors, impede currents in ac circuits.
2. **Inductive impedance** of a coil is given by

$$Z_L = j\omega L = j2\pi fL = jX_L \text{ ohms,}$$

where $j = \sqrt{-1}$, L is the inductance in henries, f is the frequency of the signal in the circuit, and $X_L = \text{Im}\{Z_L\} = \omega L = 2\pi fL$ is the **inductive reactance**. The ac voltage across a coil, V_L is equal to the product of the alternating current I in the coil and the inductive impedance Z_L of the coil; that is $V_L = IZ_L$.

3. The capacitive impedance is given by

$$Z_C = 1/(j\omega C) = 1/(j2\pi fC) = -j/(2\pi fC) = -jX_C \text{ ohms,}$$

where $X_C = 1/(\omega C) = 1/(2\pi fC)$ is the **capacitive reactance**. Note that X_C is inversely proportional to the frequency and the capacitance.

4. A series RLC circuit and its impedance phasor diagram is shown in Figure 5-2. The impedance of the series RLC circuit is

$$Z = R + Z_L + Z_C = R + j(X_L - X_C) = R + j\left(\omega L - \frac{1}{\omega C}\right).$$

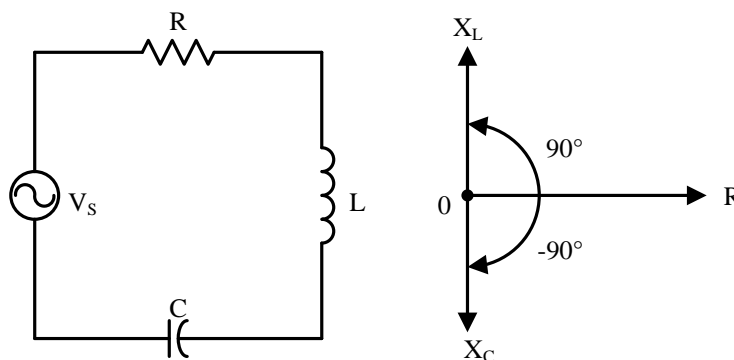

Figure 5-2: A series RLC circuit and its impedance phasor diagram.

5. Figure 5-3 illustrates how the impedance of a series RLC circuit changes with frequency. At zero frequency, both $1/(\omega C)$ and Z are infinitely large, and ωL is zero. You may

recall that at 0 Hz, the capacitor acts like an open circuit, while the inductor acts like a short circuit.

As the frequency increases, $1/(\omega C)$ decreases, and ωL increases. At the frequencies below the resonant frequency f_0 , $\omega L < 1/(\omega C)$, the circuit, whose reactance $X = \text{Im}\{Z\}$ is negative, is said to be **capacitive**. At the **resonant frequency** f_0 , $\omega L = 1/(\omega C)$, so the circuit is purely resistive and $Z = R$. At the frequencies above f_0 , $\omega L > 1/(\omega C)$, and the circuit, whose reactance $X = \text{Im}\{Z\}$ is now positive, is said to be **inductive**. The minimum magnitude of the impedance occurs at a resonant frequency f_0 where $X_L = X_C$, but increases in value when the frequency is above or below the resonant point.

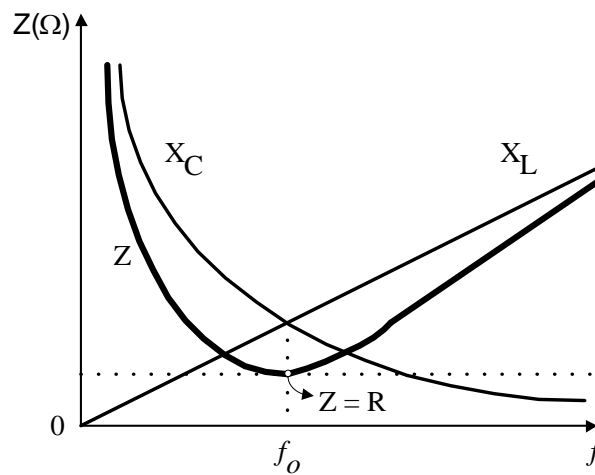

Figure 5-3: Impedance magnitude of a series RLC circuit as a function of frequency.

6. For the series RLC circuit shown in Figure 5-2, the phasor current through all the circuit elements is given by

$$I = \frac{V_s}{Z} = \frac{V_s}{R + j\left(\omega L - \frac{1}{\omega C}\right)}.$$

The phasor voltages across the resistor, capacitor, and inductor can then be found via

$$V_R = IR, \quad V_C = IZ_C, \quad \text{and} \quad V_L = IZ_L,$$

respectively. Their magnitudes are shown in Figure 5-4-1.

7. Figure 5-4-2 shows the plot of $|V_R|$. Three significant points have been marked on the curve. These are f_0 , the **resonant frequency**, and f_1 and f_2 . For series RLC circuits, the $|V_R|$ is maximum at f_0 . Note that

$$|V_R| = |I|R = \frac{|V_s|R}{\sqrt{R^2 + \left(\omega L - \frac{1}{\omega C}\right)^2}},$$

where $\omega = 2\pi f$.

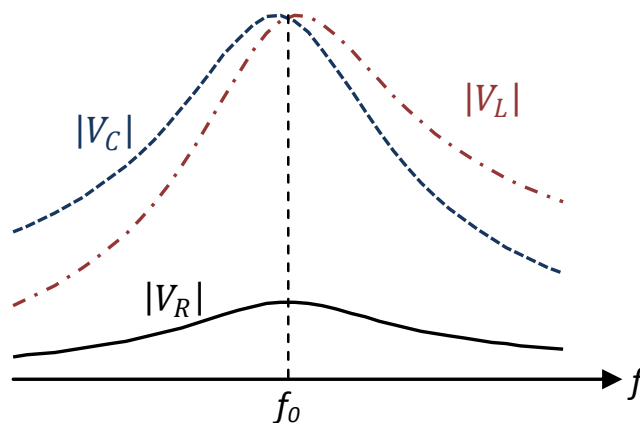

Figure 5-4-1: Voltage values across the resistor ($|V_R|$), the capacitor ($|V_C|$), and the inductor ($|V_L|$) in a series RLC circuit.

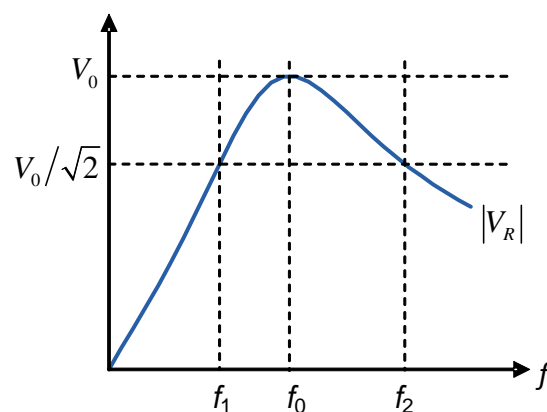

Figure 5-4-2: Frequency response of a series RLC circuit.

The frequency f (or equivalently, the angular frequency ω) that maximizes $|V_R|$ must be the one that minimizes $\left(\omega L - 1/(\omega C)\right)^2$. Because $\left(\omega L - 1/(\omega C)\right)^2$ is nonnegative, if

we can make the squared term zero then we will get the minimum of its value which in turn will maximize $|V_R|$. Therefore, the maximum value of $|V_R|$ occurs at ω such that

$$\omega L = \frac{1}{\omega C},$$

which gives

$$\omega_0 = \frac{1}{\sqrt{LC}} \text{ and } f_0 = \frac{1}{2\pi} \frac{1}{\sqrt{LC}}.$$

Points f_1 and f_2 are located at $1/\sqrt{2}$, which is approximately 70.7%, of the maximum (at f_0) on the curve. They are called the **half power** points, and the (angular) frequency separation between them is called the **bandwidth (BW)** of the circuit. For the series RLC circuit under consideration,

$$BW = 2\pi(f_2 - f_1) = \omega_2 - \omega_1 = \frac{R}{L}.$$

Remarks:

- (1) In general, the maximum values for $|V_L|$ and $|V_C|$ will **NOT** occur at resonant frequency. (See Figure 5-4-1.)
 - (2) At the resonant frequency, the voltages $|V_L|$ and $|V_C|$ across L and C , respectively, are equal.
8. For a circuit intended to be frequency selective, the sharpness of the selectivity is a measure of the circuit quality. The quality of the frequency response is described quantitatively in terms of the ratio of the resonance frequency to the bandwidth. This ratio is called the **quality factor (Q)** of the circuit. Therefore,

$$Q = \frac{\omega_0}{BW} = \frac{1}{R} \sqrt{\frac{L}{C}}.$$

III. MATERIALS REQUIRED

- Function generator, multi-meter, and oscilloscope.
- Resistor: 100 Ω , 1 k Ω .
- Inductor: 5 mH.
- Capacitors: 0.01 μF , 0.47 μF , and 0.1 μF .

IV. EXPERIMENTS

Part A: RC Circuit with Square-Wave Input

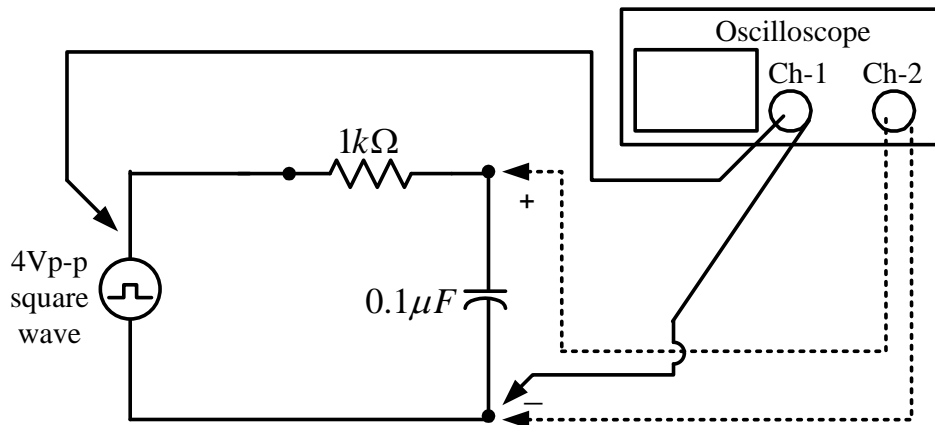

Figure 5-5: RC Circuit with Voltage Square-Wave Input

1. Connect the circuit of Figure 5-5, where the oscilloscope is in **DC mode**. Note that Channel 1 is connected to the input voltage while Channel 2 is connected to the output voltage.
2. Set the output of the function generator to be a **square wave** with amplitude of 4 V_{p-p} (2 V_{AC} on DMM) and frequency of 500 Hz. Then (use the DMM to) set the **DC offset level** to 2 V. (On the oscilloscope display, the square-wave will now has its lower peak at 0 V and its higher peak at 4 V.)
3. Adjust volts/div and time/div until a couple periods of the two waveforms can be seen on the oscilloscope. Then, draw the voltage waveforms across the function generator (shown by dash line in Figure 5-1), and across the capacitor (shown by solid line) in Table 5-1.
4. Consider the time interval where the capacitor is discharging. Find the time constant τ by measuring the time $t_{0.37}$ which is the amount of time that is needed for the voltage across the capacitor to drop from its maximum value to $1/e \approx 0.37$ times the maximum value as shown in Figure 5-1-2. Put the value of $t_{0.37}$ in Table 5-2.
5. Measure the half life t_{half} during which the voltage across the capacitor drops to half of the maximum value.
6. Calculate τ by $\tau = \frac{t_{\text{half}}}{\ln 2}$ and record the value in Table 5-2.
7. Calculate the product of R and C, and record the value in Table 5-2.

Part B: Series RLC circuit

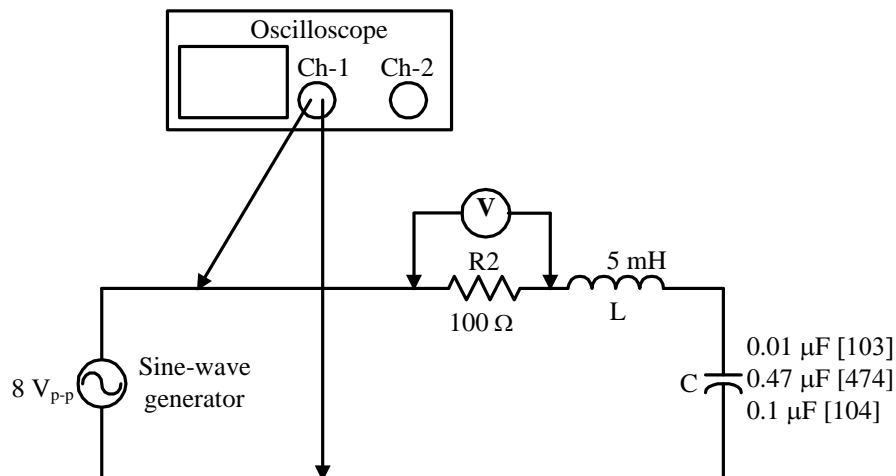

Figure 5-7: The series RLC circuit.

1. Prepare one 5 mH inductor and three capacitors with values of 0.01, 0.47 and 0.1 μF . Measure capacitance and inductance values, and calculate the resonant frequency $f_o =$

$$\omega_o/2\pi = \frac{1}{2\pi\sqrt{LC}} \text{ Hz for each of the capacitors. Record the calculated resonant}$$

frequencies in Table 5-3 under “Calculated resonant frequency”.

2. Connect the circuit of Figure 5-7 with $C = 0.01 \mu\text{F}$.
3. Set the output of the generator to 8 Vp-p voltage.

Maintain/recheck this voltage throughout this part.

4. Use the DMM to observe the rms value of the voltage V_R across the resistor as the frequency of the generator is varied. Record the resonant frequency f_o at which V_R is maximum in the “0.01 μF ” row of Table 5-3.

Caution: As you adjust the frequency f , the voltage across the generator output will change. Readjust it back to 8 Vp-p.

5. Replace the 0.01 μF with a **0.47 μF** capacitor. Check the generator output voltage to verify that it is 8 Vp-p; readjust the voltage if necessary. Find f_o and record the value in the “0.47 μF ” row of Table 5-3.
6. Replace the 0.47 μF with a **0.1 μF** capacitor. Check the generator output voltage to verify that it is 8 Vp-p; readjust the voltage if necessary. Find f_o and record the value in the “0.1 μF ” row of Table 5-3.

7. Check the generator output voltage. Keep its value at 8 Vp-p. With $C = 0.1\mu\text{F}$, vary and record the frequency according to Table 5-4.

(The value of f_0 should be the same as what you got from the previous step.)

Record the corresponding rms values of V_R , V_L , and V_C in Table 5-4, where V_L and V_C are the voltage across L and C, respectively.

Table 5-1. Square wave input voltage and voltage across capacitor

R = _____

C = _____

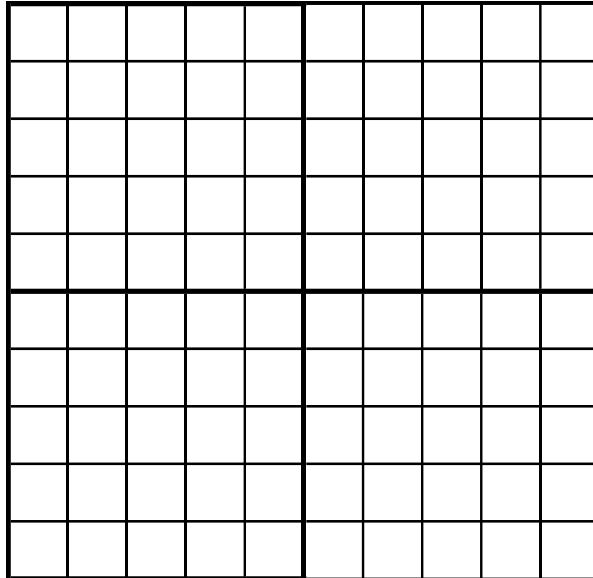

volts/div = _____, time/div = _____.

TA Signature:

Table 5-2. Time constant of an RC circuit

Measured Values		Calculated Values	
τ from $t_{0.37}$	t_{half}	τ from $t_{\text{half}} / \ln 2$	τ from RC

TA Signature:

Table 5-3. Resonant frequency of a series RLC circuit

L = _____

Inductor L, mH	Capacitor C, μF		Resonant Frequency f_0 , Hz	
			Calculated	Measured
5	0.01			
5	0.47			
5	0.1			

TA Signature: _____

Table 5-4. Frequency response of a series RLC circuit

Frequency deviation	Frequency f, Hz	Voltage across R, V_R , V	Voltage across L, V_L , V	Voltage across C, V_C , V
$f_0 - 1000$				
$f_0 - 500$				
$f_0 - 200$				
$f_0 - 100$				
f_0				
$f_0 + 100$				
$f_0 + 200$				
$f_0 + 500$				
$f_0 + 1000$				

TA Signature: _____

QUESTIONS

True or False

1. _____ In a circuit containing impedance, the current and voltage are 90 degrees out of phase.
2. _____ The value of reactance in a series RLC circuit can exceed the magnitude of impedance.
3. _____ The value of resistance in a series RLC circuit can exceed the magnitude of impedance.
4. _____ In a series RLC circuit, the capacitor rms voltage can be greater than the source rms voltage.
5. _____ A series RLC circuit operating above its resonant frequency is inductive.
6. _____ There is only one combination of L and C for each resonant frequency.

Fill in the blanks.

7. The series RLC circuit in Figure 5-2 has an inductance of 100 μH , a capacitance of 200 pF, and a resistance of 10 Ω . Determine its resonant frequency and bandwidth. Also determine X_C , X_L , I_L , and V_L at 1.0 MHz if the source voltage $V_S = 1.0 \text{ V}_p$.

Resonant frequency = _____

Bandwidth = _____

At 1.0 MHz

$X_C =$ _____

$X_L =$ _____

$I_L =$ _____

$V_L =$ _____

8. The series RLC circuit in Figure 5-2 has a capacitance of 25 μF , and a resistance of 10 Ω . We then adjust the inductance until V_R is maximum. Determine V_R , V_L , and V_C at $\omega = 2000 \text{ rad/sec}$ if the source voltage $V_S = 50 \text{ V}_p$.

$V_R =$ _____

$V_L =$ _____

$V_C =$ _____

Short Answers

9. Suppose you set the voltage across the output of the signal generator at $2V_{\text{rms}}$. You then connect the generator output across a 100Ω resistor. Now, you measure the voltage across the generator again but you get a value which is significantly less than $2V_{\text{rms}}$. Why?

10.

a) Suppose a **periodic** waveform shown on the left below is displayed when the oscilloscope is in DC mode. Carefully draw what would be shown on the oscilloscope when it is set to be in AC mode. Don't forget to explain how you get your answer.

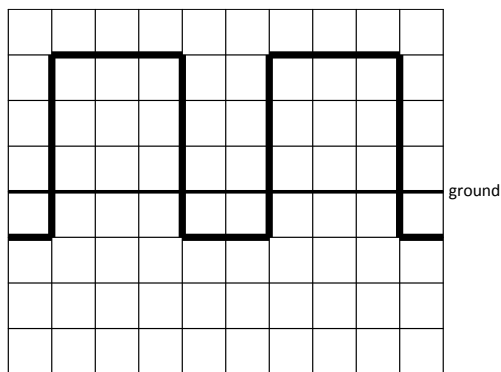

DC Mode

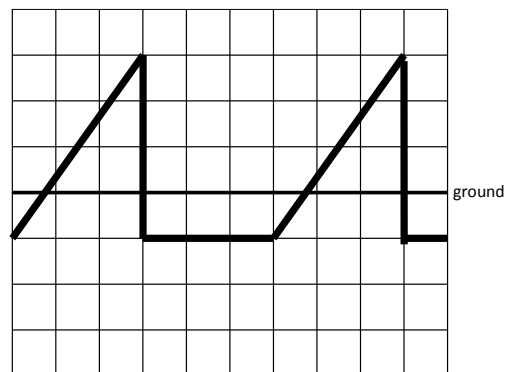

DC Mode

b) Repeat part (a) but with a new waveform shown on the right above. You may assume that the waveform is periodic with period = 6 divisions.